



# SWS Lightweight Series

Visibility & Present Weather Sensors

## USER MANUAL

INSTALLATION - OPERATION - MAINTENANCE



**SWS-100-LW**  
**SWS-200-LW**



---

**PROPRIETARY NOTICE**

The information contained in this manual (including all illustrations, drawings, schematics and parts lists) is proprietary to BIRAL. It is provided for the sole purpose of aiding the buyer or user in operating and maintaining the instrument. This information is not to be used for the manufacture or sale of similar items without written permission.

**COPYRIGHT NOTICE**

No part of this manual may be reproduced without the express permission of BIRAL.  
© 2017 Bristol Industrial and Research Associates Limited (BIRAL)



**Biral – P O Box 2, Portishead, Bristol BS20 7JB, UK**

Tel: +44 (0)1275 847787

Fax: +44 (0)1275 847303

Email: [enquiries@biral.com](mailto:enquiries@biral.com)

**[www.biral.com](http://www.biral.com)**

**Manual Number : 106018**

**Revision : 03B**

---

## **CONTENTS**

### **GENERAL INFORMATION**

Manual version.....	i
Contents list .....	ii
Figures.....	iii
Tables.....	iii
The sensors covered in this manual .....	iv
Features of the SWS Lightweight sensors .....	v
Customer satisfaction and After Sales Support .....	vi
Contacting Biral.....	vi
Two year warranty .....	vii
If you need to return the sensor.....	vii
CE Certification - safety .....	vii

### **1 SENSOR SET-UP..... 1**

1.1 STEP 1 - Unpacking the sensor .....	2
1.2 STEP 2 - Electrical Connections.....	3
1.3 STEP 3 - Equipment Test.....	6
1.4 STEP 4 - Configuration Options.....	8
1.5 STEP 5 - Installation .....	15
1.6 STEP 6 - Test And Commissioning.....	20

### **2 STANDARD OPERATING DATA ..... 24**

2.1 Standard Operating Data Message for the SWS-100 – LW .....	24
2.2 Standard Operating Data Message for the SWS-200 – LW.....	26
2.3 Data Message Variations For ALS .....	28

### **3 COMMANDS AND RESPONSES ..... 29**

3.1 Sensor Commands.....	29
3.2 Sensor Responses.....	33

### **4 MAINTENANCE PROCEDURES..... 34**

4.1 General Checks .....	34
4.2 Self-Test Codes .....	35
4.3 User Confidence Checks .....	37

### **5 CALIBRATION PROCEDURES ..... 40**

5.1 Calibration Check.....	41
5.2 Sensor Re-calibration .....	44
5.3 Precipitation Amount Calibration .....	47

### **6 PRODUCT OVERVIEW ..... 48**

6.1 SWS – LW Present Weather Sensor.....	48
6.2 Instrument Components.....	49
6.3 Accessories .....	49
6.4 Sensor Features .....	49

6.5	Present Weather Definition.....	50
6.6	Automated Measurements.....	50
6.7	Sensor Specifications.....	56
6.8	Instrument Characteristics.....	57
6.9	Digital Communication Interface.....	59
6.10	Sensor Remote Self-Test Capabilities.....	60
6.11	SWS Lightweight – external dimensions.....	61
<b>7</b>	<b>INDEX.....</b>	<b>62</b>

### **Index Of Figures**

Figure 1-1	SWS – Lightweight in packing.....	2
Figure 1-2	Cable Connectors.....	3
Figure 1-3	SWS-100 – LW Orientation.....	17
Figure 1-4	SWS-200 – LW Orientation.....	17
Figure 1-5	U-Bolt Mounting Method.....	18
Figure 4-1	Transmitter hood with white card.....	38
Figure 5-1	Calibration Plaque Mounting Details.....	41
Figure 6-1	External Dimensions of SWS – LW Sensors.....	61

### **Index Of Tables**

Table 1-1	Signal and Power Connections.....	4
Table 1-2	ALS-2 Connections.....	5
Table 1-3	Options Word (lower byte).....	8
Table 1-4	Recommended Sensor Height above Ground.....	16
Table 1-5	Remote maintenance check fields.....	22
Table 2-1	SWS-100 – LW Operating data message format.....	25
Table 2-2	SWS-200 – LW Operating data message format.....	27
Table 2-3	Message Extension for ALS-2.....	28
Table 3-1	Commands for SWS Lightweight Series of Sensors.....	30
Table 3-2	Command R? Response.....	31
Table 3-3	Command T? Response.....	32
Table 3-4	Sensor Responses.....	33
Table 6-1	Visibility Measurement Capabilities.....	51
Table 6-2	Precipitation Measurement Capabilities.....	52
Table 6-3	UK Precipitation Intensity Definitions.....	53
Table 6-4	US Precipitation Intensity Definitions.....	54
Table 6-5	SWS-100 – LW WMO Codes.....	54
Table 6-6	SWS-200 – LW WMO Codes.....	55
Table 6-7	Sensor Specifications.....	57
Table 6-8	Instrument Characteristics.....	58
Table 6-9	Digital Communication Interface Specifications.....	59

---

## General Information

The sensors covered in this manual are as follows:

Sensor Model	Capability
<b>SWS-100 – LW</b>	Visibility Precipitation type identification

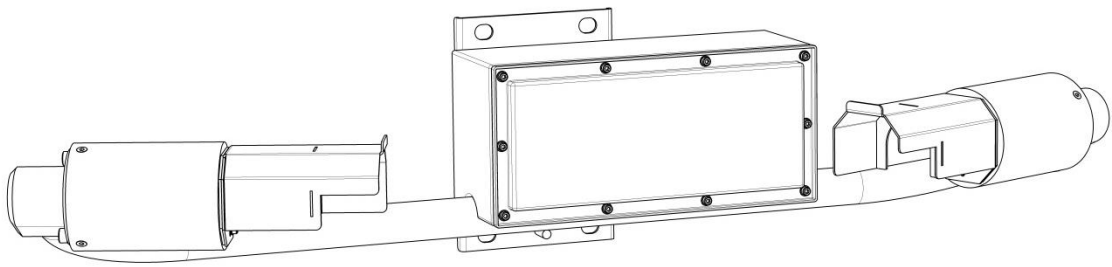

---

<b>SWS-200 – LW</b>	Visibility Precipitation type identification
---------------------	---

*This model has an extra backscatter receiver for:*

Rain rate  
Snowfall rate  
Precipitation accumulation

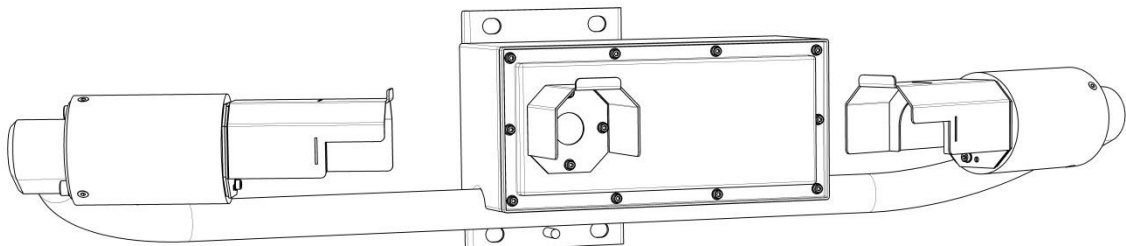

---

### **PATENT COVERAGE**

The Present Weather Measurement Techniques are protected by the following Patents.

U.S. Patent No.	4,613,938
Canadian Patent No.	1,229,240
German Patent No.	3,590,723



**RoHS  
compliant**

## **Thank you for choosing Biral as your supplier of present weather sensors**

A great deal of time has been invested at Biral to offer the best combination of sensor performance and value and almost three decades of experience and knowledge have been incorporated into the SWS series. We are confident that they will provide you with many years of accurate operation.

### **Features of the SWS Lightweight Sensor:**

- **full date/time stamp in data string** provided by the real time onboard clock
- **easy installation** due to its light weight and small footprint
- **low power consumption**, designed for intermittent battery operation
- **identification of precipitation type as well as accumulation**

There are currently two sensors in the SWS – Lightweight sensor range. These are the SWS-100 – LW and the SWS-200 – LW. Either of these can be supplied to be used with the Biral Ambient Light Sensor, model ALS-2. Throughout this manual the term SWS – LW Sensor is used to refer to features common to both these sensors.

---

## **Customer Satisfaction**

At Biral we set our standards high and only your complete satisfaction is acceptable to us. If you believe your experience has not met these standards we would be grateful if you would contact us so we can rectify any issues you may have (equally, if you have any positive experiences you would like to share).

## **After Sales Support**

Biral offers support by telephone and email for the lifetime of these sensors, even if there has been a change of ownership, so please get in touch if you require help. Similarly, if you have any questions about your new equipment we are only a mouse-click or telephone call away. Our contact details are provided below.

*(NB For your convenience our contact details are also on the label fixed to your sensor).*

## **Contacting Biral**

If you would like technical assistance, advice or you have any queries regarding the operation of the sensor please do not hesitate to contact us.

<p><b>For enquiries and technical support:</b></p>
Contact us by telephone on : + 44 (0)1275 847787
Contact us by fax on : + 44 (0)1275 847303
Contact us by e-mail at : <a href="mailto:service@biral.com">service@biral.com</a>



---

## **Two year warranty**

The SWS – LW Present Weather Sensors come with a two year limited warranty against defective materials and workmanship. If you have any questions about the warranty please contact Biral.

In order to help us to assist you please be sure to include the following information:

- Model of equipment
- Serial number of equipment
- Nature of defect
- Your full name, address and contact details
- Relevant application details and data output
- Responses to R? command

## **If you need to return the sensor**

The SWS – LW sensors should give you many years of trouble-free service but in the unlikely event that the equipment proves to be faulty and we have asked you to return the sensor to us please address the equipment to:

BIRAL  
Unit 8 Harbour Road Trading Estate  
Portishead  
Bristol BS20 7BL  
UNITED KINGDOM

*NOTE: the customer is responsible for the shipping costs.*

## **CE Certification - Safety**

All Biral's SWS - LW sensors comply with the requirements for CE marking. Once installed, it is the user's responsibility to ensure that all connections made to the sensor comply with all Local and National safety requirements.

---

[INTENTIONALLY BLANK]

# 1 SENSOR SET-UP

The format of this section is such that it logically follows these recommended procedural steps:

**Step 1** – Unpack equipment and ensure that all required parts are supplied and identified.

**Step 2** – Make electrical connection as required for testing and configuration.

**Step 3** – Power up and test equipment on bench.

**Step 4** – Configure equipment as required for site installation.

**Step 5** – Installation including siting considerations, height, orientation, mounting and electrical grounding.

**Step 6** – Carry out commissioning test procedure.

*NOTE: Many of the tests specified within this manual require the use of a PC or equivalent. To achieve the two-way serial communication required, Biral recommends the use of a PC running the Biral Sensor Interface Software. If this software is not available, use a terminal program - for example Windows® Hyper Terminal™. The Biral Sensor Interface Software is available from our website ([www.Biral.com](http://www.Biral.com)), or contact Biral at: [enquiries@biral.com](mailto:enquiries@biral.com).*

## 1.1 STEP 1 - Unpacking the sensor

The sensor is packed in a foam filled shipping container and is fully assembled ready for use.



The sensor is delivered with:

- U-bolts for pole mounting
- Power and Data cable
- Documentation
- Other optional items you may have ordered

**Figure 1-1 SWS – Lightweight in packing**

### **Other optional components you may have ordered**

#### **Calibration Kit**

The calibration kit in a protective carrying case, containing: a calibration screen, mounting arm and connector (referred to as the calibration reference plaque when assembled), 3 grey foam plugs (see section 5, Calibration Procedures, for application) and a calibration arm mounting bracket.

#### **Mains Adapter**

A mains adapter to operate the sensor using mains power.

#### **Power and Signal Cable**

As standard a 6m Power and Data cable is supplied. Any additional cable length must be specified at time of order.

#### **Calibration Arm mounting Bracket**

This bracket is used when a field calibration of the sensor is required.

## 1.2 STEP 2 - Electrical Connections

**ALL ELECTRICAL CONNECTIONS SHOULD BE COMPLETED BEFORE  
APPLYING POWER TO THE SENSOR**

### 1.2.1 Cable

The SWSLW series sensors are supplied as standard with a 6m cable. This cable is a 3 twisted pair cable all wires, 22awg (7/30) with over-all foil screen and drain wire and a nominal diameter of 8.1mm.

*Note: For RS232 data configuration, cable lengths above 6m will not work reliably at high baud rates. It is strongly recommended that baud rates no higher than 4800 are used for cable lengths up to 25m.*

### 1.2.2 Connector – Standard

A Power and Data connector is fitted to the sensor. This carries power to the sensor and the two way digital signals between the sensor and the host processor.

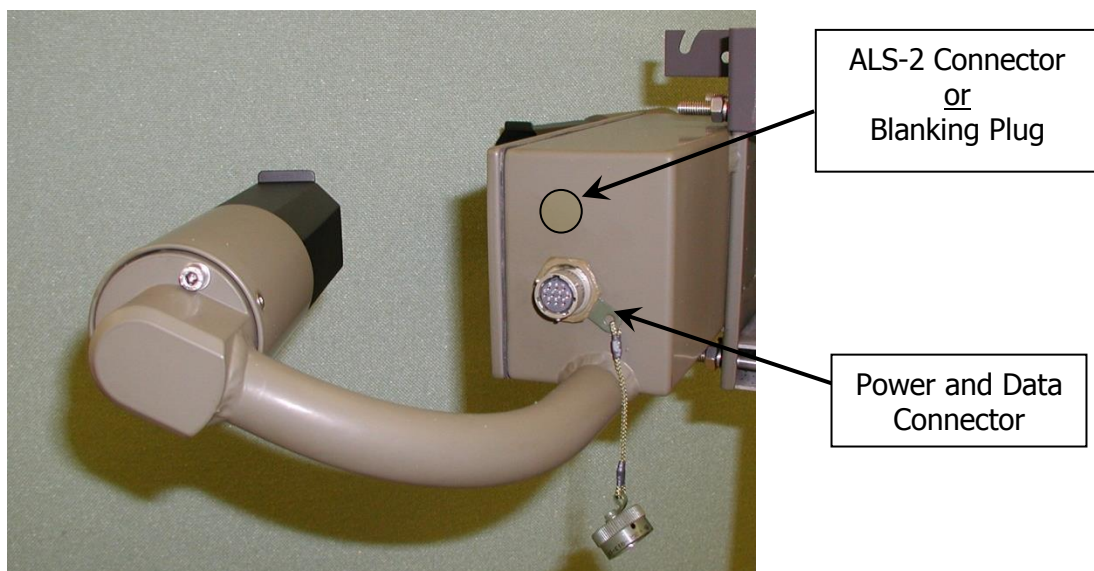

**Figure 1-2 Cable Connectors**

The Power and Data connector is military grade conforming to MIL-C-24682 Series I. Any connector fully compatible with MIL-C-24682 may be used. The connector used is an Amphenol, type 62GB-57A12-10PN. A suitable mating cable mounting plug is: Amphenol 62GB-56T12-10SN, being a 10-way, size 12 with socket inserts.

The connections are as follows:

Pin Number	Supplied Cable Colour	Function
A	-	N.C.
B	-	N.C.
C	White ]	Signal Ground
D	Black ]	RS232 – Tx (sensor output)
E	White ]	Signal Ground
F	Brown ]	RS232 – Rx (sensor input)
G		N.C.
H		N.C.
J	White ]	Power – Negative
K	Red ]	Power – Positive

**Table 1-1 Signal and Power Connections**

### Connecting the power supply:

All models in this range require an input voltage supply between 9 and 36V DC. This is typically 24V DC supply at 2.9W. This will rise to 4.6W if the Non-Dew window heaters are used.

### Pin Connections for RS232 Signal

The sensors can only be operated with RS232 communications. RS232 may be used up to 100 m but reliable communications cannot be guaranteed for more than 40 m. The connections are as above.

### 1.2.3 Connectors – ALS-2 Option

If the sensor is ordered with the option of the additional ambient light sensor (ALS-2), the SWS – LW sensor will have a second connector for the ALS-2, in the position shown in Figure 1-2 Cable Connectors. This mates with the connector supplied on the ALS-2 cable, as detailed below.

The connector used is military grade conforming to MIL-C-24682 Series I. Any connector fully compatible with MIL-C-24682 may be used. The actual type on this instrument is an Amphenol, 62GB-57A10-07SN, being a 7-way, size 10 with socket inserts. A suitable mating cable mounting plug is: Amphenol 62GB-56T10-07PN.

The connections are as follows:

Pin Number	Function
A	Power to ALS-2 – Negative
B	Power to ALS-2 – Positive
C	RS232 Ground
D	RS232 – Tx (sensor output)
E	RS232 – Rx (sensor input)
F	N.C.
G	N.C.

**Table 1-2 ALS-2 Connections**

If the ALS-2 option has not been specified, a blanking plug may be located in this position.

### 1.3 STEP 3 - Equipment Test

Biral recommends that the equipment is powered and checked on the bench before site installation. This is to ensure that you are comfortable with the functionality of the sensor and to pre-empt any queries that arise before attempting site installation.

*Note: this procedure assumes a default configuration for the sensor - please check Calibration Certificate supplied with your sensor for specific configuration details.*

**NOTE: In this test, and in all subsequent sections of this manual, the following convention MUST be observed:  
ALL COMMANDS SHOULD BE TERMINATED WITH <CARRIAGE RETURN> AND <LINE FEED> (ASCII CHARACTERS 13 AND 10). In this manual this is normally abbreviated to <CRLF>.**

#### 1.3.1 Equipment Test Procedure

1. Connect the power pins on the input connector to a local power source (do not turn power source on). Connect sensor earth lug to earth (this may not be necessary but can help prevent communication errors with certain PCs).
2. Connect the signal cable to a PC running the Biral Sensor Interface Software. If this is not available, use a terminal program - for example Windows® Hyper Terminal™.
3. Configure the terminal program, either the Biral Sensor Interface Software or Hyper Terminal as follows:

##### **Default Interface Parameters**

Baud Rate.....	9600
Data Bits .....	8
Stop Bits.....	1
Parity .....	None
Flow Control .....	None

(If using Hyper Terminal the options 'Send line ends with line feeds' and 'Echo typed characters locally' in ASCII set up should be checked).

4. Turn the local power source "ON".



If communications are working the sensor will respond with "Biral Sensor Startup".

5. Check Data Transmission To Sensor:

Send the command R? from the PC terminal to the sensor:

The sensor will respond with its Remote Self-Test & Monitoring Message.

For example:

100,2.509,24.1,12.3,5.01,12.5,00.00,00.00,100,105,107,00,00,00,+021.0,4063

6. Check Data Transmission From Sensor:

If the sensor is NOT in polled mode:

Wait for the sensor to transmit a Data Message (approx. 80 seconds from power up).

If the sensor is in polled mode:

Send the command D? from the PC terminal to the sensor:

A Data Message will be transmitted immediately.

7. MOR Calibration check:

Carry out the calibration check procedure in section 5, page 40 to ensure that the MOR value changes (i.e. the sensor responds to changes in visibility).

*NOTE: as this calibration check is being carried out indoors the MOR value will NOT agree with that marked on your calibration reference plaque.*

NB The sensor is fully calibrated before it leaves Biral.

**THIS PROCEDURE CAN ONLY BE COMPLETED IF A SUITABLE  
SWS – LW CALIBRATION KIT AND PC ARE AVAILABLE**

### 1.4 STEP 4 - Configuration Options

There are a number of configuration options available for the user to select.

Two options (date and time enable and checksum enable) are set using a configuration byte of the **Options Word**, detailed in sections 1.4.1 to 1.4.3. The remaining options are set using a configuration byte of the **Operating State** word. These are set directly using commands starting with "OS". Each of these is detailed below in sections 1.4.5 to 1.4.6.

#### 1.4.1 Options Word

The options word consists of two bytes. Their current values can be determined by sending the "OP?" command. The reply will be as follows:

**aaaaaaaa,bbbbbbbb**

The upper byte, (aaaaaaaa) is used to set internal operating parameters and should not be changed. It will in general be '00000000'. For the lower byte, a value is entered as a binary number (1's and 0's). Leading 0's in the value need not be entered. The value is stored in non-volatile memory and the operating configuration when power is applied is that set by the last entered options word. The definition of each bit of this byte is shown below (Table 1-3). **Note:** the first bit is bit 8, the last bit being bit 1.

Each bit of the lower byte of the **Options Word** is defined as follows:

b b b b b b b b

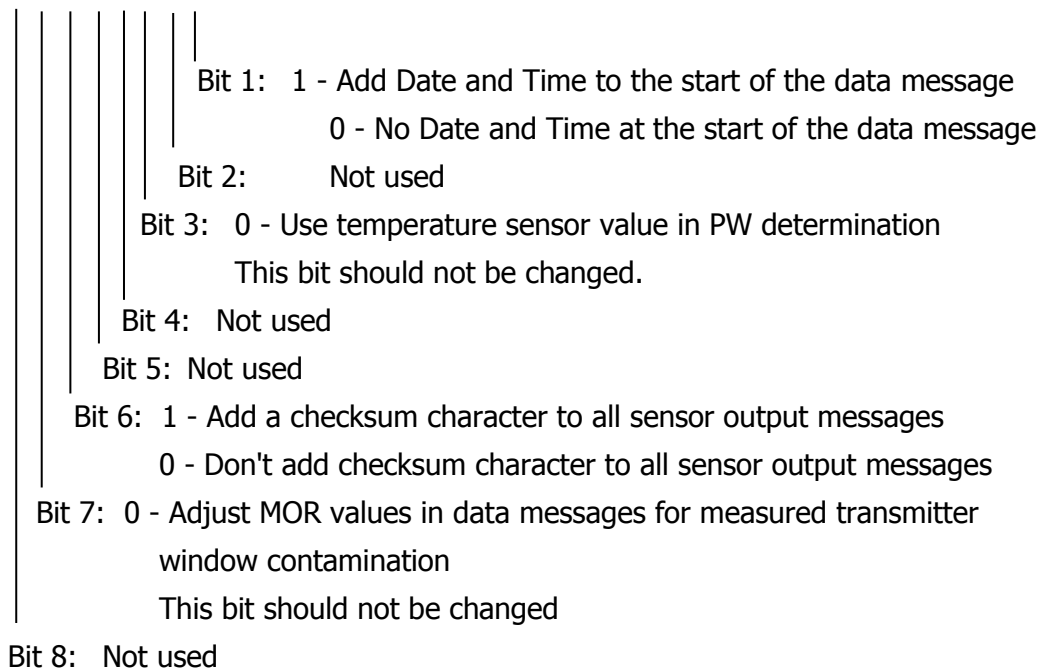

**Table 1-3 Options Word (lower byte)**

To set this word, send command CO to enable changes and then command OP00a0000b to set the Option Word as required. For example, send OP100000 to enable the checksum with no date and time stamp.

Bit 1 (Date and Time Stamp enable) and Bit 6 (Checksum enable) are the only bits which may be set to '1' by the user. All other bits MUST be left at '0' for correct sensor operation. The functions controlled by this byte are detailed in sections 1.4.2 to 1.4.3. The Default setting = 00000000.

#### 1.4.2 Date and Time Stamp in data string

By default the date and time stamp is not included at the start of the data string. This is controlled by the Options Word setting; see Table 1-3 Options Word (lower byte).

##### To enable Date and Time stamp

The sensor can be configured to generate messages with the date and time string by setting the least significant bit in the options word:

Step 1 - Send the command: CO.

Step 2 - Send the command: OP1.

*(Note: to enable checksum and time/date-stamp send OP100001).*

**PLEASE BE EXTREMELY CAREFUL IN SETTING THE CORRECT BIT IN STEP 2  
AS SETTING THE WRONG BIT WILL RESULT IN THE SENSOR FUNCTIONING  
INCORRECTLY**

To check the setting of the options word, send the command: OP?

The sensor should respond: 00000000,00000001.

##### To disable Date and Time stamp

To disable the date and time stamp, send the command OP0 in step 2 above.

##### To read the current Date and Time

Send the command TR?

The sensor will respond with the date / time message e.g.:

FRIDAY ,19\12\14,13:15:25,179

*Note: the final '179' is a time calibration figure, set during final test.*

**To set the current Date and Time**

There are two commands required to set the current date and time:

%SD sets the real time clock date.

The format of the command is: %SDWDDMMYY

where:

W - is the day of the week (1..7) with Sunday being 7

DD - is the date (01..31)

MM - is the month (01..12)

YY - is the year (00..99)

The sensor will respond with 'OK'.

%ST sets the real time clock time.

The format of the command is: %STHHMMSS

where:

HH - is the hours in 24 hour clock (00..23)

MM - is the minutes(00..59)

SS - is the seconds (00..59)

The sensor will respond with 'OK'.

### 1.4.3 Checksum to verify message

A checksum byte can be included with messages sent by the sensor to verify that noise in the communications link has not changed the message. Generally noise is not a problem and checksum verification is not required. This is controlled by the Options Word setting; see Table 1-3 Options Word (lower byte)

By default the sensor is configured at the factory with checksum DISABLED.

#### To enable checksum

The sensor can be configured to generate messages with a checksum byte by setting the sixth bit in the options word:

Step 1 - Send the command: CO.

Step 2 - Send the command: OP100000.

*(Note: to enable checksum and time/date-stamp send OP100001).*

**PLEASE BE EXTREMELY CAREFUL IN SETTING THE CORRECT BIT IN STEP 2  
AS SETTING THE WRONG BIT WILL RESULT IN THE SENSOR FUNCTIONING  
INCORRECTLY**

To check the setting of the options word, send the command: OP?

The sensor should respond: **0000000,00100000M.**

(NB. M is the checksum character).

#### To disable checksum

To disable the checksum send the command OP0 in step 2 above.

The checksum character is positioned after the message and before the end characters (<crLf>). The checksum value is between 0 and 127, and is the sum modulo 128 (the remainder after the sum is divided by 128) of all the ASCII values of the characters in the message except the end characters. The checksum value is replaced by its bit wise complement if it happens to be any of the following: ASCII 8 (backspace), ASCII 10 (linefeed), ASCII 13 (carriage return), ASCII 17 through ASCII 20 (DC1 through DC4), or ASCII 33 (exclamation point '!').

For Message:

C1 ... Cm <cksum><crLf>

The calculation is as follows:

$$\langle cksum \rangle = \left( \sum_{n=1}^m c_n \right) \text{MOD} 128$$

IF <cksum> = 8 THEN <cksum> = 119

IF <cksum> = 10 THEN <cksum> = 117

IF <cksum> = 13 THEN <cksum> = 114

IF <cksum> = 17 THEN <cksum> = 110

IF <cksum> = 18 THEN <cksum> = 109

IF <cksum> = 19 THEN <cksum> = 108

IF <cksum> = 20 THEN <cksum> = 107

IF <cksum> = 33 THEN <cksum> = 94

#### 1.4.4 Communications Configuration

The SWS – LW sensors use RS232C signal level voltages only.

### 1.4.5 Automatic message setting

The sensor can be set to send a data message automatically after each data collection period, or to send a data message only when requested (polled sensor). The default setting is for automatic data transmission. To check which method is programmed send the message:

OSAM?

The sensor will send the reply:

00 = Automatic message transmission disabled

01 = Automatic message transmission enabled

To set the sensor to the required automatic message setting, send the message:

OSAMx

Where x is:

0 = Automatic message transmission disabled

1 = Automatic message transmission enabled

The sensor will respond with "OK".

### 1.4.6 Window heater operating setting

The sensor can be set to have the window heaters disabled, permanently enabled, or for them to be controlled according to contamination levels. The default setting is for window heaters enabled and on. To check which configuration is programmed send the message:

OSWH?

The sensor will send the reply:

00 = Window heaters disabled

01 = Window heaters enabled and on

02 = Window heaters enabled and controlled according to contamination levels

To set the sensor to the required window heater configuration, send the message:

OSWHx

Where x is:

0 = Window heaters disabled

1 = Window heaters enabled and on

2 = Window heaters enabled and controlled according to contamination levels

The sensor will respond with "OK".

*Note: The SWS-200 LW does not have a heated window on the backscatter head.*

### 1.4.7 Baud Rate Configuration

Default communication parameters are 9600 Baud, 8 data bit, 1 stop bit, no parity, and no flow control. The baud rate may be changed if required as follows.

Send      %B(Number)

Just typing %B will bring up the different baud rate options:

```
SELECT REQUIRED BAUDRATE BY TYPING %B(NUMBER)
1....1200 BAUD
2....2400 BAUD
3....4800 BAUD
4....9600 BAUD
5....19K2 BAUD
6....38K4 BAUD
7....57K6 BAUD
```

Select the baud rate to use, for example to select 4800 baud the user would type

%B3<CRLF>

The user then receives a prompt to send an "OK" to the sensor at the new baud rate setting. The new setting will only be accepted if the user manages to communicate with the sensor at the new baud rate within 60 seconds. Otherwise the sensor will reset and continue operation with the original baud rate settings. If an "OK" command is received at the new baud rate the sensor will update its settings and restart.



## 1.5 STEP 5 - Installation

Please consider the following factors when installing the sensor:

- (1) Siting considerations.
- (2) Height of the sensor above ground.
- (3) Orientation of the sensor.
- (4) Mounting the sensor.
- (5) Electrical grounding.

Each of these factors is covered in more detail below:

### 1.5.1 Siting Considerations

**Pollutants** – Care should be taken to ensure that the sensor is situated away from any possible sources of pollutants (for example car exhausts, air-conditioning outlets etc). Particulates entering the sensor's sample volume will cause errors in the reported visibility measurements.

**Reflected Light** – Care should be taken to ensure that the sensor is situated away from any causes of reflected light (for example walls, trees and people etc). Reflected light entering the sensor's optics will cause errors in the reported visibility measurements.

**Air-flow** – Care should be taken to ensure that the sensor is situated away from objects that disrupt the 'normal' flow of air to and through the sensor sampling volume (for example walls, trees and other equipment etc).

**RFI Interference** – In addition to the above mentioned natural effects that may influence the performance of the sensor, due regard should also be given to radiated electrical interference. Sources of potential interference include radio antennas and radiated transients from high-voltage plant located near to the sensor installation.

### 1.5.2 Height Above Ground:

The optimum height at which to mount the sensor depends on the application. The table below shows recommended heights.

Application	Typical height	Comment
Highway fog-warning systems	1.5 to 2 meters (4.9 to 6.6 feet)	Recommended height for the sensor sample volume is the average distance of a vehicle driver's eyes above the roadway.
Airport applications	4.3 meters (14 feet) above the runway	This is the standard height for visibility sensors in the U.S. This height may differ in other countries.
General meteorological	1.8 meters (6 feet)	This is a suitable height unless the particular application dictates otherwise.

**Table 1-4 Recommended Sensor Height above Ground**

### 1.5.3 Orientation of the SWS – LW Sensor

The orientation of the sensor heads should be such that the rising or setting sun does not appear in the field-of-view of the receiver lenses.

*It is desirable to avoid sunlight from flooding the receiver optics and to avoid sunlight induced noise spikes from creating false precipitation counts, although false-alarm algorithms in the sensors invariably eliminate such false counts.*

The recommended orientation is shown in the following two diagrams (Figure 1-3 and Figure 1-4).

For the SW-100 – LW sensor, the optimum position is with the receiver head pointing directly due North.

For the SWS-200 – LW, the optimum position is with the forward scatter receiver and the back scatter receiver oriented equally either side of due North. This is with the backscatter head pointing 34° East of North.

For sensors located in the Southern hemisphere,  $180^\circ$  should be added to the above directions. That is, for the SWS-200 – LW point the backscatter head  $34^\circ$  West of South, and for the SWS-100 – LW, point the forward scatter receiver directly due South.

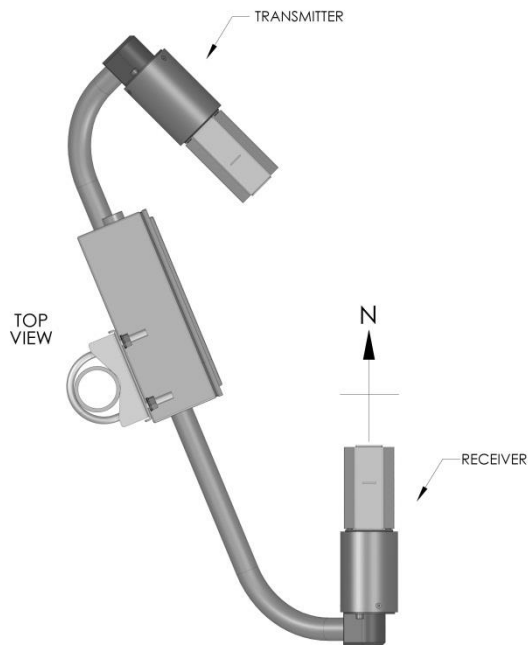

**Figure 1-3 SWS-100 – LW Orientation**

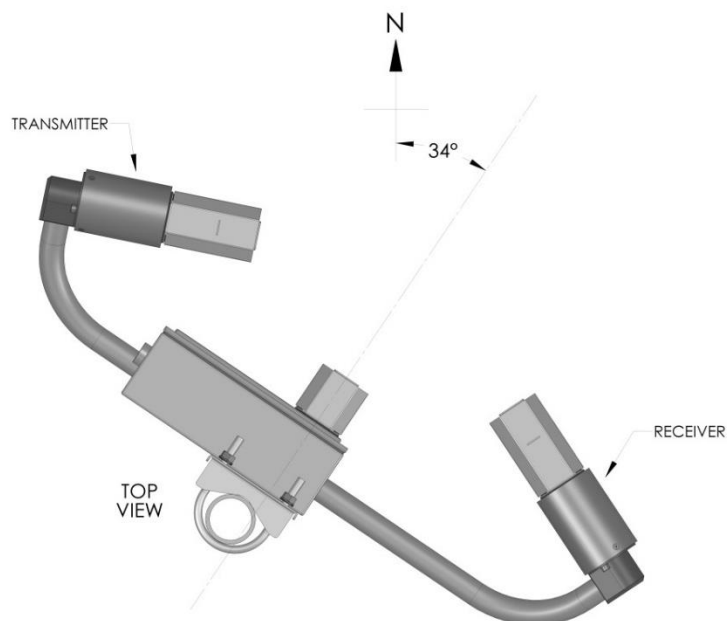

**Figure 1-4 SWS-200 – LW Orientation**

### 1.5.4 Mounting the Sensor:

#### On a pole

Two stainless steel U-bolts and saddles are provided for securing the sensor to the top of the mast. The two V-block saddles oppose the U-bolt, thus providing a secure grip on the mast. The sensor can be mounted on a galvanised steel pipe or heavy walled aluminium tube with an outer diameter between 40 to 64 mm. For mast diameters outside this range the U-bolts provided will not be suitable.

*Note: pipe sizes often refer to their inside diameter; some 60 mm (ID) pipe may be too large for the U-bolts to fit around.*

The sensor head should be mounted near the very top so that the mast will not interfere more than necessary with the free flow of fog or precipitation through the sample volume. The flat stainless steel washers should be placed next to the powder coated surface of the mounting plate to prevent gouging by the lock washers as the nuts are tightened.

Calibration Plaque Mounting Bracket

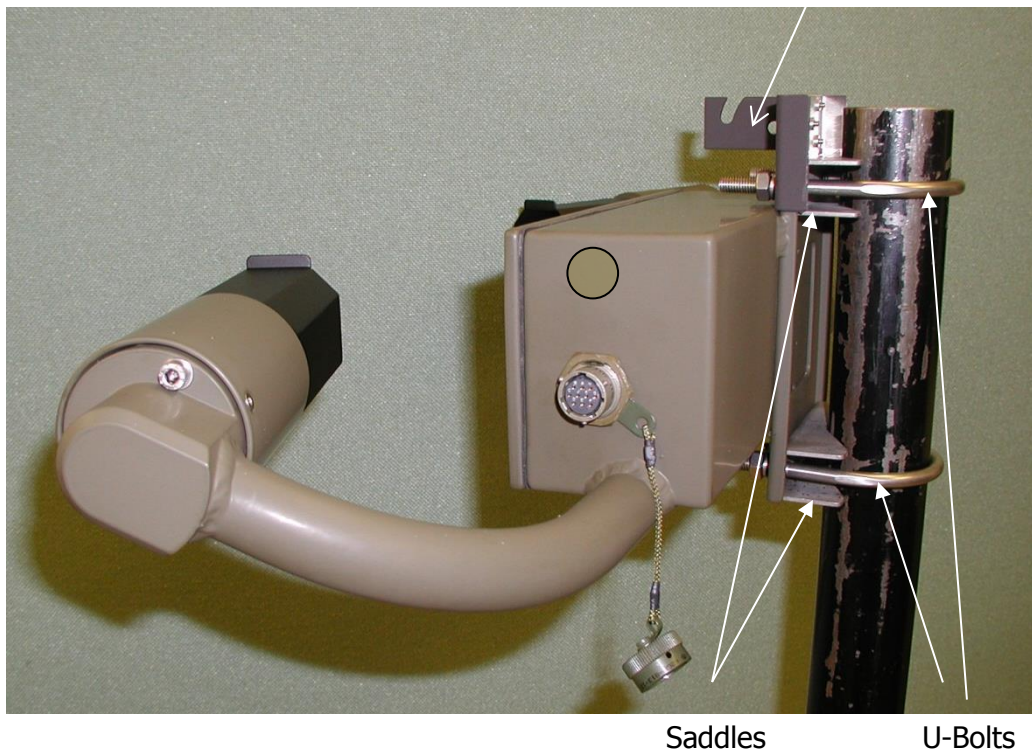

**Figure 1-5 U-Bolt Mounting Method**

*Note, In Figure 1-5 U-Bolt Mounting Method, a calibration plaque mounting plate is shown attached to the top U-bolt mounting. This is only required if calibration is to be checked using the optional calibration assembly, see section 5 Calibration Procedures.*

**On a wall**

The sensor can be bolted directly to a flat surface using the four mounting holes provided. Every effort should be made to ensure that the mounting surface has minimal effect on the air flow and the precipitation flow through the sample volume. Even if mounted at the top of a wall, the airflow will be restricted, reducing the accuracy of the sensor in certain atmospheric conditions.

**1.5.5 Electrical Grounding**

Possible instrument failure can result from the damaging effects of over-voltage transients induced on the power line and the signal distribution lines.

Destruction of sensitive components can result from unprotected lines, or instrument failure may occur over a long period of time due to slow device degradation. Destructive over volt transients can occur in many ways; e.g., lightning induced transients, AC power line transients and EMI/RFI electromagnetic noise. The power/control subsystem of the sensor contains transient surge-arrestors on all power and signal lines as a standard feature. EMI filters are present on the power and lines entering the power/control subsystem.

**It is essential to connect the sensor to earth ground for maximum protection of the instrument. In addition, if relays are in use and are required to switch mains voltages, protective earth bonding will be required to conform with national and local installation safety requirements.** The following notes are intended to provide some guidance in the design and construction of an electrical grounding system.

- (1) Ground Rod: An eight-foot ground rod should be used to make contact with moist soil during even the driest periods.
- (2) Lead Lengths: No. 6 AWG solid copper wire should be used to connect the instrument (and thus the transient voltage suppressers) to the ground rod. Use the shortest and most direct paths to the ground. Simply connect the ground lead to the grounding screw provided on the front of the lower mounting flange of the instrument.
- (3) System Interconnections: Eliminate all isolated ground loops. The shield of the signal output cable, for example, should be attached only at one end of the cable and left floating at the other end. Preferably, it should be attached to ground at the sensor end of the signal cable.
- (4) Connections: Use tight-corrosion-proof bare metal connections throughout the grounding system.

## 1.6 STEP 6 - Test And Commissioning

The following steps contain a few basic checks to provide confidence that the unit will functioning correctly after installation.

**These checks are recommendations only and are neither essential nor exhaustive.**

### 1.6.1 Checking Power Supply

Before connecting the power to the sensor, the supply voltage being provided should be measured to ensure that the voltage present is compatible with the sensor power requirement. Use a multimeter to measure the supply voltage which should be between 9V and 36V DC.

**DANGER of electric shock!**

**Exercise caution when performing this measurement.**

**WARNING**

**Only connect power to the sensor if it matches the voltage requirements of the sensor. Damage caused by improper voltage connection is not covered under warranty.**

### 1.6.2 Checking Data link

1. Connect the cable to a local power source (do not turn power source on).
2. Connect the signal wires to a PC running the Biral Sensor Interface Software. If this is not available, use a terminal program - for example Windows® Hyper Terminal™.
3. Configure the terminal program as follows:

**Default Interface Parameters**

Baud Rate.....	9600
Data Bits .....	8
Stop Bits.....	1
Parity .....	None
Flow Control .....	None

4. Turn the local power source "ON".

If communications are working the sensor will respond with "Biral Sensor Startup".

5. Check Data Transmission To Sensor:

Send the command R? from the PC terminal to the sensor:

The sensor will respond with its Remote Self-Test & Monitoring Message.

For example:

```
100,2.509,24.1,12.3,5.01,12.5,00.00,00.00,100,105,107,00,00,00,+021.0,4063
```

6. Check Data Transmission From Sensor:

If the sensor is NOT in polled mode:

Wait for the sensor to transmit a Data Message (approx. 80 seconds from power up).

If the sensor is in polled mode:

Send the command D? from the PC terminal to the sensor:

A Data Message will be transmitted immediately.

### 1.6.3 Remote Self-Test Check

Check that the values in the Remote Self-Test & Monitoring Message from the previous Data Link check are within the ranges indicated below, in Table 1-5 Remote maintenance check fields.

Field 1: Space	Message starts with a space
Field 2: 100 or 108	Heater state and error flags
Field 3: 2.450 - 2.550	Internal Reference voltage
Field 4: 9.00 - 36.00	Supply Voltage
Field 5: 10.8 -13.2	Internal operating voltage
Field 6: 4.5 - 5.5	Internal operating voltage
Field 7: 10.8 -13.2	Internal operating voltage
<i>Field 8: 00.00</i>	<i>Not applicable in this check</i>
<i>Field 9: 00.00</i>	<i>Not applicable in this check</i>
Field 10: 85 - 105	Transmitter power monitor
Field 11: 80 - 120	Forward Receiver monitor
Field 12: 80 - 120	Back Receiver monitor
Field 13: 00 - 99	Transmitter Window Contamination
Field 14: 00 - 99	<i>Not applicable in this check</i>
Field 15: 00 - 99	<i>Not applicable in this check</i>
Field 16:	Temperature °C
Field 17 3300-4200	ADC Interrupts per second

**Table 1-5 Remote maintenance check fields**



### 1.6.4 Calibration Check

The sensor is fully calibrated before it leaves Biral. However, if you would like to carry out a user confidence calibration check please follow the calibration check procedure in section 5 page 40 to ensure that the MOR value changes i.e. the sensor responds to changes in visibility.

**THIS PROCEDURE CAN ONLY BE COMPLETED IF A SUITABLE  
SWS LW CALIBRATION KIT IS AVAILABLE**

### **CONGRATULATIONS**

**YOUR SENSOR SHOULD NOW BE FULLY CONFIGURED, TESTED AND  
INSTALLED READY FOR USE**

#### **THE REMAINDER OF THIS MANUAL COVERS:**

- **STANDARD DATA MESSAGES**
- **COMMANDS AND RESPONSES**
- **OPERATIONAL AND MAINTENANCE PROCEDURES**
- **CALIBRATION CHECK AND RE-CALIBRATION PROCEDURE**
- **SENSOR DETAILS AND SPECIFICATIONS**

## 2 STANDARD OPERATING DATA

When in standard mode a data message will be output from the sensor every measurement period (default 60 seconds). When in polled mode the same message is output only in response to the D? command. The operating mode is checked by sending command "OSAM?". The standard mode (default) is selected if the response is "01". If the response is "00", the polled mode is selected. Instructions for setting this configuration are provided in section 1.4.5 page 13.

*Note: All responses from the sensor are appended with carriage return and line feed characters (<crLf>, see section 1.3).*

### 2.1 Standard Operating Data Message for the SWS-100 – LW

The data message format is:

**<Date>,<Time>,SWS100,NNN,XXX,AA.AA KM,BB.BBB,CC,±DD.D C,EE.EE KM,FFF<cs><crLf>**

MESSAGE	MEANING
<b>&lt;Date&gt;</b>	Optional Date string in the form DD/MM/YY.
<b>&lt;Time&gt;</b>	Optional Time string in the form HH:MM:SS.
<b>SWS100</b>	SWS100 message prefix.
<b>NNN</b>	Instrument identification number set by the user.
<b>XXX</b>	Averaging Time period in seconds.
<b>AA.AA KM</b>	Meteorological Optical Range (km). This is the averaged value.
<b>BB.BBB</b>	Not used in the SWS-100 – LW. Set to 99.999.

MESSAGE	MEANING
<b>CC</b>	<p>Present weather codes. From WMO Table 4680 (Automatic Weather Station).</p> <p>XX Not Ready (first 5 measurement periods from restart).            00 No Significant weather observed.            04 Haze or smoke.            30 Fog.            40 Indeterminate precipitation type.            50 Drizzle.            60 Rain.            70 Snow.</p>
<b>±DD.D C</b>	Not used in the SWS-100 – LW. Set to 99.9 C.
<b>EE.EE KM</b>	Meteorological Optical Range (km). This is the instantaneous value.
<b>FFF</b>	<p>Self-test and Monitoring (see section 4.2):            F F F</p> <p>           O = other self-test values OK.            X = other self-test faults exist.</p> <p>           O = windows not contaminated.            X = window contamination warning – cleaning recommended.            F = Window contamination fault – cleaning required.</p> <p>           O = sensor not reset since last "R?" command.            X = sensor reset since last "R?" command.            T = sensor in Test Mode</p>
<b>&lt;CS&gt;</b>	If selected this will be the checksum character. The checksum is off by default.

**Table 2-1 SWS-100 – LW Operating data message format**

A typical data message from an SWS-100 – LW sensor is as follows:

SWS100,001,060,00.14 KM,99.999,30,+99.9 C,00.14 KM,XOO

## 2.2 Standard Operating Data Message for the SWS-200 – LW

The data message format is:

**<Date>,<Time>,SWS200,NNN,XXX,AA.AA KM,BB.BBB,CC,±DD.D C,EE.EE KM,FFF<cs><crf>**

MESSAGE	MEANING
<b>&lt;Date&gt;</b>	Optional Date string in the form DD/MM/YY.
<b>&lt;Time&gt;</b>	Optional Time string in the form HH:MM:SS.
<b>SWS200</b>	SWS200 message prefix.
<b>NNN</b>	Instrument identification number set by the user.
<b>XXX</b>	Averaging Time period in seconds.
<b>AA.AA KM</b>	Meteorological Optical Range (km). This is the averaged value.
<b>BB.BBB</b>	Amount of water in precipitation in last measurement period (mm).
<b>CC</b>	Present weather codes. From WMO Table 4680 (Automatic Weather Station).  XX Not Ready (first 5 measurement periods from restart). 00 No Significant weather observed. 04 Haze or smoke 30 Fog 40 Indeterminate precipitation type 51 Light Drizzle 52 Moderate Drizzle 53 Heavy Drizzle 61 Light Rain 62 Moderate Rain 63 Heavy Rain 71 Light Snow 72 Moderate Snow 73 Heavy Snow 89 Hail
<b>±DD.D C</b>	Temperature (°C).
<b>EE.EE KM</b>	Meteorological Optical Range (km). This is the instantaneous value.



### 2.3 Data Message Variations For ALS

For SWS – LW sensors fitted with an Ambient Light Sensor, the data output strings are identical to the standard message with the following appended to the message, prior to the optional checksum <cs> and the carriage return and line feed <crLf>.

**,ALS,±AAAAA,BBB**

Message	Meaning
<b>ALS</b>	ALS data message prefix.
<b>±AAAAA</b>	ALS Signal, 1 minute averaged value (cd/m <sup>2</sup> ).
<b>BBB</b>	ALS Self-Test and Monitoring (see section 4.2). <div style="display: flex; align-items: flex-start;"> <div style="border-left: 1px solid black; border-right: 1px solid black; border-bottom: 1px solid black; width: 20px; height: 100px; margin-right: 5px;"></div> <div style="display: flex; flex-direction: column; gap: 10px;"> <div style="display: flex; align-items: center;"> <div style="border-right: 1px solid black; width: 10px; height: 10px; margin-right: 5px;"></div> <div>O = Other self-test values OK. X = Other self-test fault exists.</div> </div> <div style="display: flex; align-items: center;"> <div style="border-right: 1px solid black; width: 10px; height: 10px; margin-right: 5px;"></div> <div>O = Window not contaminated. X = Window contaminated – cleaning recommended/required. F = Window contaminated – fault. S = Sensor input saturated.</div> </div> <div style="display: flex; align-items: center;"> <div style="border-right: 1px solid black; width: 10px; height: 10px; margin-right: 5px;"></div> <div>O = Sensor not reset since last "R?" command. X = Sensor reset since last "R?" command.</div> </div> </div> </div>

**Table 2-3 Message Extension for ALS-2**

A typical data message from an SWS-200 – LW sensor with an ALS-2 is as follows:

SWS200,001,060,00.13 KM,00.000,30,+24.5 C,00.13 KM,XOO,ALS,+00118,000

*NOTE: If the ALS-2 is configured but not connected the Self-Test and Monitoring characters are set to "FFF" and the ALS signal set to +99999.*

## 3 COMMANDS AND RESPONSES

### 3.1 Sensor Commands

*NOTE: All commands should be terminated with <Carriage Return> and <Line Feed> (<crLf>, see section 1.3).*

Command	Function	Response	Applicability SWS-	
			100	200
<b>A?</b>	Send accumulated precipitation message. (Accumulated precipitation in mm) ,(Accumulation time in minutes).	<b>xxx.xx (xxxx.x) ,xxxx</b>		✓
<b>AC</b>	Clear accumulated precipitation.	<b>OK</b>		✓
<b>BB?</b>	Send instantaneous value of backscatter EXCO.	<b>±xxx.xx</b>		✓
<b>BL?</b>	Send instantaneous value of Total EXCO less precipitation particle component.	<b>±xxx.xx</b>		✓
<b>BT?</b>	Send instantaneous value of Total EXCO .	<b>±xxx.xx</b>	✓	✓
<b>CA</b>	Perform precipitation amount calibration (Calibration must be enabled).	<b>See section 5.3</b>		✓
<b>CE</b>	Perform both forward scatter and backscatter (Not SWS-100 – LW) EXCO calibration. (Calibration must be enabled).	<b>See section 5.2</b>	✓	✓
<b>CO</b>	Enable calibration.	<b>OK</b>	✓	✓
<b>CX</b>	Disable calibration.	<b>OK</b>	✓	✓
<b>D?</b>	Send latest data message.	<b>See section 2</b>	✓	✓
<b>IDx</b>	Set instrument identification number displayed in data message. Range x = 1 to 999. (Default = 1).	<b>OK</b>	✓	✓
<b>OP?</b>	Check Option Word configuration.	<b>See section 1.4.1</b>	✓	✓
<b>OPxxxxxxxx</b>	Set configuration options. See <b>section 1.4.1.</b>	<b>OK</b>	✓	✓
<b>OSAM?</b>	Check automatic message setting.	<b>See section 1.4.5</b>	✓	✓
<b>OSAMx</b>	Set automatic message setting, <b>section 1.4.5.</b>	<b>OK</b>	✓	✓

Command	Function	Response	Applicability SWS-	
			100	200
<b>OSWH?</b>	Check window heater setting.	<b>See section 1.4.6</b>	✓	✓
<b>OSWHx</b>	Set window heater setting. See <b>section 1.4.6.</b>	<b>OK</b>	✓	✓
<b>PV?</b>	Send program version message.	<b>SI xxxx.yy</b>	✓	✓
<b>R?</b>	Send remote self-test and monitoring message.	<b>See section 3.1.1</b>	✓	✓
<b>RST</b>	Restart instrument.	<b>OK</b>	✓	✓
<b>SN?</b>	Send instrument serial number.	<b>Jxxxx.xx</b>	✓	✓
<b>T?</b>	Send instrument times message.	<b>See section 3.1.2</b>	✓	✓
<b>TAx</b>	Set auxiliary measurement sample period. Range x= 2-20 (seconds). (Default = 5).	<b>OK</b>	✓	✓
<b>TEST,tt,vv.vv,f,c,ww</b>	Start Stop Test Mode	<b>See section 3.1.3</b>		
<b>TMx</b>	Set measurement interval. Range x = 10-300 (seconds). (Default= 60).	<b>OK</b>	✓	✓
<b>TR?</b>	Send current date and time. <b>See section 1.4.2.</b> (The final ,000 is an internal fixed constant).	<b>FRIDAY , 23/03/12, 13:15:25,000</b>	✓	✓
<b>WT?</b>	Send current window contamination threshold for warning indication.	<b>XX See section 4.2</b>	✓	✓
<b>WTx</b>	Set window contamination threshold for a warning indication, % transmission. Range: 0 to 30 (%) (Calibration must be enabled). (Default = 10). <b>See section 4.2</b>	<b>OK</b>	✓	✓
<b>%Bx</b>	Set communication baud rate. Range 1-7.	<b>See section 1.4.7</b>	✓	✓
<b>%SDWDDM MY</b>	Set current date. <b>See section 1.4.2.</b>	<b>OK</b>	✓	✓
<b>%STHHMMS S</b>	Set current time. <b>See section 1.4.2.</b>	<b>OK</b>	✓	✓

**Table 3-1 Commands for SWS Lightweight Series of Sensors**



### 3.1.1 Command R? - Send Remote Self-Test and Monitoring Message

Example response:

**100,2.509,24.1,12.3,5.01,12.5,00.00,00.00,100,105,107,00,00,00,+021.0,4063**

The various fields in the response are as follows:

Field 1: **Space**                      The message starts with a space.

Field 2: **ABC**                        Heater state and error flags.

A=1 - Window heaters ON.

A=2 - Not used.

A=4 - A/D Control signal error.

B=1 - EPROM checksum error.

B=2 - Non-volatile memory checksum error.

B=4 - RAM error.

C=2 - Ired commanded OFF.

C=4 - Receiver test in progress (Ired OFF).

C=8 - Sensor power reset since last R? Command.

or any combination of these.

Field 3: 2.450 - 2.550      Internal Reference voltage.

Field 4: 9.00 - 36.00        Supply Voltage.

Field 5: 11.5 - 14.0        Internal operating voltage.

Field 6: 4.5 - 5.5            Internal operating voltage.

Field 7: 11.5 - 14.0        Internal operating voltage.

Field 8: 0.00 - 6.00        Forward Scatter background brightness.

Field 9: 0.00 - 6.00        Backscatter background brightness (not SWS-100 – LW).

Field 10: 85 - 105            Transmitter power monitor.

Field 11: 80 - 120           Forward Receiver monitor.

Field 12: 80 - 120           Back Receiver monitor (not SWS-100 – LW).

Field 13: 00 - 99            Transmitter Window Contamination.

Field 14: 00 - 99            Not Used.

Field 15: 00 - 99            Not Used.

Field 16:                        Temperature °C.

Field 17: 3300-4200         ADC Interrupts per second.

**Table 3-2 Command R? Response**

### 3.1.2 Command T? - Send Instrument Times Message

Response: <b>aaaa,bbbb,cccc,dddd</b>	
<b>aaaa:</b>	Measurement interval for each operational data message (10 to 300 seconds) (default = 60).
<b>bbbb:</b>	Auxiliary measurement sample period - time between measurement of peripheral signals during measurement interval. (2 to 20 seconds) (default = 5).
<b>cccc:</b>	Not used.
<b>dddd:</b>	Not used.

**Table 3-3 Command T? Response**

### 3.1.3 TEST Command – Start / Stop Test Mode

The test mode allows the user to force the data message to contain user-defined data for visibility, present weather, window contamination and fault status for a fixed period of time. The test mode is identified by the first character in the self-test data section of the message set to a 'T'.

To initiate the Test Command send the command "**CO<crLf>**", followed by the TEST command in the format:

**TEST,tt,vv.vv,f,c,ww<crLf>**

Where:

- tt** = Duration of test in minutes – range 00-60 (00 will stop the test)
- vv.vv** = Visibility will be in km – range 0.01 to maximum range, 7.5
- f** = Fault Indicator – Digit (range 0-1) indicating Other fault status (0=No Fault, 1 = Fault)
- c** = Contamination Indicator – digit (range0-2) indicating contamination, (0=None, 1=Warning, 2=fault)
- ww** = Weather Code - corresponds to WMO 4680 weather code (00-89)

Example:

CO  
TEST,02,07.50,0,0 – Outputs a visibility of 7.5km for 2 min (Clear conditions)

TEST,06,00.10,0,0 – Outputs a visibility of 0.1km for 6 min (Foggy conditions)

**TEST,00** – Stops the test and resets the sensor.

The test settings will be output in the data message.

The output of the sensor will be the standard sensor message with the visibility, weather code, window contamination and fault status set to the required values.

The sensor will exit test mode and reset at the end of the test duration.

### 3.2 Sensor Responses

<b>RESPONSE</b>	<b>MEANING</b>
<b>BAD CMD</b>	Your command was not understood by the sensor. Check the text of the command and re-send.
<b>COMM ERR</b>	An error was detected in a character in the command. Re-send the command.
<b>OK</b>	Command with no quantitative response was understood and executed.
<b>TIMEOUT</b>	Command was sent with more than 10 seconds between characters. Re-send the command.
<b>TOO LONG</b>	Command message was longer than 24 characters including end characters. Re-send the command.

**Table 3-4 Sensor Responses**

## 4 MAINTENANCE PROCEDURES

The SWS Lightweight sensors require very little maintenance. The following sections detail the checks that are advisable to ensure continued good operation of the sensor. The frequency of these checks depends upon the location and environmental conditions under which the sensor operates.

It is suggested that a general check, plus window cleaning should take place typically at three monthly intervals. This period may be increased or decreased dependent on the contamination determined during these inspections. It is also recommended that a calibration check (see section 5.1) is carried out at six monthly intervals to verify that the instrument is still continuing to perform within the specification.

Section 4.2, Self-Test Codes, describes the meaning of the self-test codes provided in all the standard data messages. It specifies what actions, if any, are required to restore the sensor to full operational capability.

### 4.1 General Checks

A general check of the physical condition of the sensor should be carried out at regular intervals. Particular attention should be paid to the condition of the cable from the side of the unit. It is suggested that this is carried out at least every three months, in conjunction with window cleaning (see 4.1.2 below).

#### 4.1.1 De-mister Heaters (fitted as standard to all sensors)

The window de-misters are low powered heaters designed primarily to prevent condensation. They maintain the temperature of the windows at a few degrees above ambient temperature.

The default setting is ON. See section 1.4.5 for details.

The warmth may be detected with the finger on the window but is easier to detect using a thermometer with surface temperature probe. The windows should be between 5 and 10°C above ambient temperature after at least 10 minutes operation. Ensure that windows are cleaned after coming into contact with the skin.

*NOTE: The backscatter window, on the main body of the SWS-200 – LW sensor is not heated.*

### 4.1.2 Window Cleaning

The SWS – LW is an optical instrument and is therefore susceptible to accumulation of contaminants on the windows in the hoods. The windows should be cleaned by gently wiping the windows using a pure alcohol (propanol) and a soft cloth (*appropriate safety precautions must be taken when using pure alcohol*).

The SWS Lightweight sensor is fitted with a Transmitter Window monitoring systems which compensates for contamination and will flag an error when the contamination reduces the signal by more than a pre-set amount (default 10%) for at least 5 minutes - when this error flag occurs all windows should be cleaned at the earliest possible opportunity. If the contamination continues to increase up to a pre-set limit of 30%, the appropriate part of the remote maintenance and self-test message in the sensor Data Output Message changes from X (warning) to F (fault) – see section 2 and section 4.2.2. The accuracy of the instrument, if operated at greater contamination levels, may begin to deteriorate. The windows require cleaning as a matter of urgency.

## 4.2 Self-Test Codes

Self-Test and Monitoring information is provided in the standard Operating Data Message. This information consists of three alpha-numeric characters which have the following meanings.

*NOTE: The command "R?" provides a response with full diagnostic information. The extent of this information depends on the sensor configuration specified at time of purchase. This response is detailed in section 3.1.1.*

### 4.2.1 Most Significant Character (Sensor Reset Flag)

This will be set to "X" on start-up. It will only be set to "O" following receipt of an "R?" command. If it subsequently is set to "X", this is an indication that a fault, such as a power interruption, has caused the processor to reset. This is generally of no importance, but may assist in the diagnosis of any other problem which may have occurred previously.

### 4.2.2 Central Character (Window Contamination)

All SWS – LW sensors have monitoring of contamination on the transmitter window. The processor compensates the visibility reading to allow for this contamination and also checks the contamination figure against a value of either

10% (default value) or 30%. This Self-test code can be one of three characters, O, X or F dependent on the contamination reading received. These have the following meaning:

- "O":** Window contamination is less than 10% (Default value; can be adjusted by the user, see command WT<sub>x</sub>, section 3.1). No action required.
- "X":** Window contamination warning. The window contamination is between 10% and 30% for at least 5 minutes. The visibility reading provided is corrected utilising this contamination figure, but it is recommended that the windows are cleaned at the earliest possible opportunity.
- "F":** Window contamination fault. The window contamination is above 30%. Although the visibility reading is still corrected using this contamination figure, the accuracy may deteriorate as the contamination increases. The windows require cleaning.

*NOTE: The ALS has an additional code of "S". This indicates that the sensor is saturated with a VERY bright light source (such as direct view of the sun). Although the reported light level will be in error, it can be implied that the true ambient light level is high.*

#### 4.2.3 Least Significant Character (Other Self-Test errors)

A variety of operating parameters are regularly checked against normal operational figures as an early warning of possible sensor faults. This character indicates whether all parameters other than window contamination are normal. This Self-test code can be one of two characters, O, or X. These have the following meaning:

- "O":** No Fault. No action required.
- "X":** Internal error. Send command "R?" to list all internally monitored parameters. Check against section 3.1.1 to determine the cause of this error. Send command "RST" to restart the sensor. If the fault persists, arrange for the sensor to be serviced at the earliest possible opportunity.

### 4.3 User Confidence Checks

**The following user confidence checks require bi-directional communications with a PC running the Biral Sensor Interface Software. If this is not available, use a terminal program - for example Windows Hyper Terminal.**

It is suggested that these should be carried out at least every year, to provide continuing confidence in the correct operation of the system.

#### 4.3.1 MOR Calibration Check

If you wish to carry out a user confidence calibration check please follow the calibration check procedure in section 5, page 40 to ensure that the MOR value changes ie the sensor responds to changes in visibility.

**THIS PROCEDURE CAN ONLY BE COMPLETED IF A SUITABLE  
SWS – LW CALIBRATION KIT AND PC ARE AVAILABLE**

#### 4.3.2 Window Monitor Checks

The SWS Lightweight sensors monitor the transmitter window for contamination. The values measured are used to adjust the MOR value, and are also used to determine when the windows should be cleaned.

The performance of the monitoring circuits can be checked by the following procedures:

##### **Transmitter Window Monitor**

- Step 1.** Clean the transmitter window.
- Step 2.** Send the command: R?
- Step 3.** Verify that the 'Transmitter Window Contamination' field value is 00 to 02.
- Step 4.** Insert a white card (or paper) in the transmitter hood that blocks and almost touches the window (see Figure 4-1 Transmitter hood with white card).

**Step 5.** Send the command: R?

**Step 6.** Verify that the 'Transmitter Window Contamination' field value is much greater than 10 (eg 99).

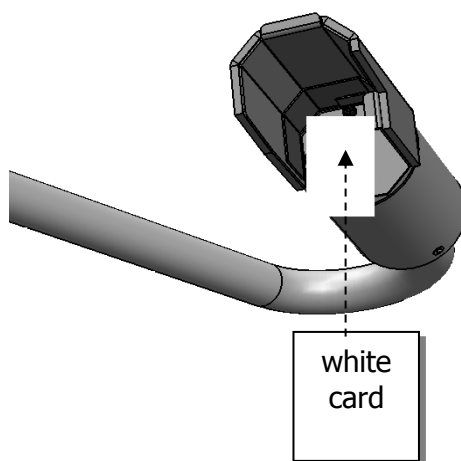

**Figure 4-1 Transmitter hood with white card**

**Step 7.** Remove the white card.

#### 4.3.3 Receiver Background Brightness Measurement Checks

The receiver background brightness value measures the optical signal detected by the receiver caused by the intensity of the ambient background. This value is used to set the threshold values for precipitation particle detection and interpretation. The following procedure will check this function (this procedure is used for both the forward scatter and backscatter receivers). For the SWS-100 – LW only carry out the forward scatter test.

**Step 1.** Insert grey foam plugs ('Zero Plugs', supplied in the calibration kit) into the forward scatter receiver hood (and back scatter hood if applicable), blocking all light from the window.

**Step 2.** Send the command: R?

**Step 3.** Verify that the value in the 'Forward (Back) Scatter Receiver Background Brightness' field in the sensor response (see section 3.1.1) is less than 00.06.

**Step 4.** Remove the zero plugs from the Sensor Head receiver hoods.



**Step 5.** While shining a flashlight directly into the receiver window send the command: R?

*NOTE: This test requires the use of a filament bulb flashlight. There is insufficient IR radiation from a visible LED source to carry out this test successfully.*

**Step 6.** Verify that the value in the 'Forward (Back) Scatter Receiver Background Brightness' field is much greater than 00.06.

## 5 CALIBRATION PROCEDURES

This section explains how to CHECK the calibration of the sensor and ONLY IF NECESSARY how to recalibrate it.

**ALL THE PROCEDURES IN THIS SECTION REQUIRE  
A SWS – LW CALIBRATION KIT**

The Meteorological Optical Range (MOR) calibration of the forward scatter channel and the backscatter channel are checked by the procedure outlined below.

The Calibration Reference Plaque used for the calibration check has been assigned a forward scatter value which is a simulation of a MOR expressed in kilometres. This value is shown on the label on the black plastic connector which attaches the arm to the calibration screen.

The SWS Lightweight plaque also has a backscatter value which although it also is expressed in kilometres, is an artificial value assigned only for the purpose of checking that the sensitivity of the backscatter channel is within its proper limits.

The SWS Lightweight sensor requires a calibration plaque mounting bracket to be attached to the support pole using the upper sensor U-Bolt mounting. This bracket is supplied with the calibration kit, but can be supplied separately if more than one sensor is to be calibrated using a single calibration kit. This bracket is shown in place in Figure 5-1 Calibration Plaque Mounting Details.

The round calibration screen should first be attached to the calibration arm, and this assembly should then be attached to the mounting bracket as shown in Figure 5-1 Calibration Plaque Mounting Details.

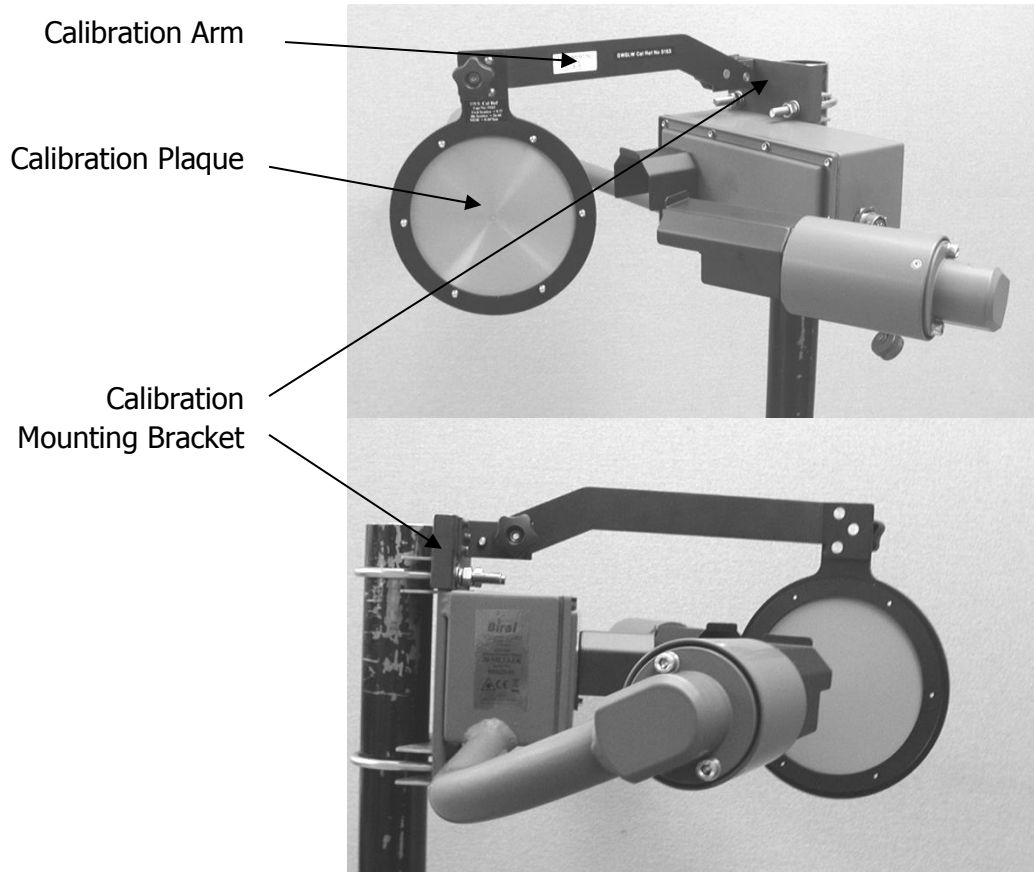

**Figure 5-1 Calibration Plaque Mounting Details**

## 5.1 Calibration Check

The following instructions describe how to check the calibration of a SWS-Lightweight sensor. This procedure can only be completed with:

1. A SWS – LW Calibration Kit.
2. Connection to a PC running the Biral Sensor Interface Software, or, if this is not available, terminal emulation software (such as Windows® Hyper Terminal™) using the serial data connector. *If you need help with this please do not hesitate to contact us (contact details on page vi).*

*Note: All commands should be terminated with <Carriage Return> and <Line Feed> <crLf>, (see section 1.3).*

**CALIBRATION CHECK NOTES**

PLEASE READ THESE NOTES BEFORE CONTINUING

The MOR (Meteorological Optical Range or visibility) values depend heavily on the location and prevailing weather conditions and should only be carried out with the sensor:

- 1. MOUNTED OUTSIDE AND ON A CLEAR DAY (VISIBILITY>10KM)**
- 2. POWERED FOR AT LEAST 1 HOUR**
- 3. NOT LOCATED NEAR A WALL OR OTHER OBSTRUCTION**
- 4. NOT RECEIVING OPTICAL REFLECTIONS (FROM SURFACES OR CLOTHING)**

STEP 1: Clean all windows on the sensor using pure alcohol (propanol) and soft cloth or tissue, preferably lens tissue. Check the cleanliness using a portable light if possible.

*(Step 1 may not be necessary if checking or commissioning a new sensor).*

STEP 2: Attach the calibration reference plaque to the sensor as shown in Figure 5-1 (power to the sensor need not be removed). Do not stand close to the sensor during calibration as reflections may cause errors in the reported values.

**MOR Zero Check:**

STEP 3: Insert GREY FOAM PLUGS in the front of each window blocking out all light. (There are 3 foam plugs top left in the calibration case, only 2 are needed for the SWS-100 – LW).

STEP 4: Send the command "RST<crLf>". Verify the response "OK".

STEP 5: If the sensor is operating in the polled mode, send the "D?" command at 60 seconds intervals. (If the sensor is set to automatically output data then the sensor will output data every 60 seconds.)

- STEP 6: Wait for the fifth (5<sup>th</sup>) data message from the sensor. Verify that the forward-scatter MOR (located in 4<sup>th</sup> field) is the maximum range set for the sensor under test.
- STEP 7: **SWS-200 – LW Only.** Send the command "BB? <crLf>".  
Verify that the response value is  $000.00 \pm 0.20$
- STEP 8: Remove the foam plugs.

**MOR gain Check:**

- STEP 9: Send the command "RST<crLf>" to restart the sensor.  
Verify the response is "OK".
- STEP 10: If the sensor is operating in the polled mode, send "D?" command at 60 seconds intervals. (If the sensor is set to automatically output data then the sensor will output data every 60 seconds.)
- STEP 11: Wait for the fifth (5<sup>th</sup>) data message from the sensor. Verify that the forward-scatter MOR (located in 4<sup>th</sup> field) is within  $\pm 10\%$  of the value assigned to the calibration reference plaque (the value on the label attached to the plaque).
- STEP 12: Send the command "BB? <crLf>".  
Verify that the response value is within  $\pm 20\%$  of the value assigned to the calibration reference plaque.
- STEP 13: Remove the calibration reference plaque from the sensor.

**If the results of the calibration check have agreed with the value on the label attached to the calibration reference plaque re-calibration is NOT required.**

**A re-calibration is required ONLY if the MOR values are outside those on the calibration reference plaque AND the calibration check has been carried out ACCORDING TO THE CALIBRATION CHECK NOTES on page 42.**

## 5.2 Sensor Re-calibration

**RE-CALIBRATING THE METEOROLOGICAL OPTICAL RANGE  
SHOULD ONLY BE CARRIED OUT IF THE SENSOR HAS FAILED A  
CORRECTLY PERFORMED USER CONFIDENCE CHECK**

**WARNING**  
**ERRORS DURING THIS RE- CALIBRATION PROCEDURE WILL CAUSE THE  
SENSOR TO GIVE INCORRECT DATA**

**BEFORE CONTINUING ENSURE THAT THE SENSOR:**

- 1. IS MOUNTED OUTSIDE AND THAT VISIBILITY IS GREATER THAN  
10KM.**
- 2. HAS BEEN IN CONTINUOUS OPERATION FOR AT LEAST 1 HOUR.**
- 3. WINDOWS ARE CLEAN.**
- 4. IS NOT LOCATED NEAR A WALL OR OTHER OBSTRUCTION.**
- 5. IS NOT RECEIVING OPTICAL REFLECTIONS (from surfaces or  
clothing).**

***Note: All commands should be terminated with <Carriage Return> and  
<Line Feed> <crLf>, (see Section 1.3).***

- STEP 1.** Set up the sensor with the calibration reference plaque in place - see section 5.1 (power to the sensor need not be removed).
- STEP 2.** Send command CO.  
Sensor replies: OK.
- STEP 3.** Send command: CE.  
Sensor replies:  
CLEAN WINDOWS,  
BLOCK FWD SCAT RCVR OPTICS,  
BLOCK TRANSMITTER OPTICS  
BLOCK BK SCAT RCVR OPTICS (*not for the SWS-100 – LW*)  
INSTALL REF STD,  
ENTER FWD SCAT VALUE  
FORM: XXX.XX
- STEP 4.** Fit the grey foam plugs (supplied with the calibration kit) against all three of the windows (only two needed for the SWS-100 – LW).
- STEP 5.** Enter Forward CAL value from the calibration plaque.
- STEP 6. SWS-200 – LW Only**  
Sensor replies:  
ENTER BACK SCAT VALUE  
FORM: XXX.XX  
Enter Backscatter CAL value from the calibration reference plaque.
- STEP 7.** Sensor replies:  
CAL IN PROGRESS  
Wait for approximately 2 minutes.  
Sensor replies:  
REMOVE OPTICS BLOCKS,  
ENTER "OK"
- STEP 8.** Remove grey foam plugs from all windows and send text: OK.  
Sensor replies:  
CAL CONTINUES
- STEP 9.** Wait for approximately 2 minutes.

Sensor replies:

CAL COMPLETE  
REMOVE REF STD

*Note: Do not remove the calibration reference plaque at this point.*

- STEP 10.** Wait for the third data message to be received at the PC.
- STEP 11.** Note the forward-scatter MOR (located in 4<sup>th</sup> field) in the sensor data message.
- STEP 12.** Send the BB? Command and note the value.
- STEP 13.** If the MOR reported is the same as the MOR value of the plaque ( $\pm 0.01$ ) and the response to the BB? command is within 5% of the Backscatter calibration value of the plaque then the sensor is within its calibration limits. The sensor can be returned to its operational configuration with confidence. The calibration reference plaque can now be removed.



### 5.3 Precipitation Amount Calibration

*Note: All commands should be terminated with <Carriage Return> and <Line Feed> <crLf>, (see section 1.3).*

This section is only applicable to model SWS-200 – LW.

This process provides for adjusting the calibration factor of the sensor precipitation measurement. The amount of adjustment to this factor is determined by making an independent measurement of the liquid accumulation over several rain episodes and comparing the accumulation reported by the sensor to this independently measured accumulation.

The value to be entered to adjust the precipitation amount factor is calculated as follows:

$$\text{Value entered} = \frac{\text{Desired precipitation accumulation}}{\text{Sensor's reported precipitation accumulation}} * 100$$

**EXAMPLE:** Over several rainstorms, a reference sensor measures an accumulation of 225 millimetres. The SWS sensor reported an accumulation of 244 millimetres. To adjust the sensor's precipitation accumulation factor, the value to be entered is:

$$\frac{225}{244} \times 100 = 92.2$$

The procedure to be used for precipitation amount calibration is as follows:

**STEP 1.** Send the parameter command: "CO". The sensor replies: OK.

**STEP 2.** Send the precipitation amount calibration command: "CA". Sensor replies:

ENTER PRECIP AMT ADJ FACTOR  
IN PERCENT (30.0 TO 300.0)  
FORM: XXX.X

**STEP 3.** Send the required adjustment factor: (e.g. 92.2). Sensor replies:

CAL COMPLETE

**STEP 4.** The precipitation amount calibration process is complete.

## 6 PRODUCT OVERVIEW

### 6.1 SWS – LW Present Weather Sensor

The SWS Lightweight Present Weather Sensor is a special version of the SWS series of sensors, designed for lower weight and lower power consumption. Two models are available in the range, with the following measurement capabilities:

Sensor Model	Capability
<b>SWS-100 – LW</b>	Visibility Precipitation type identification

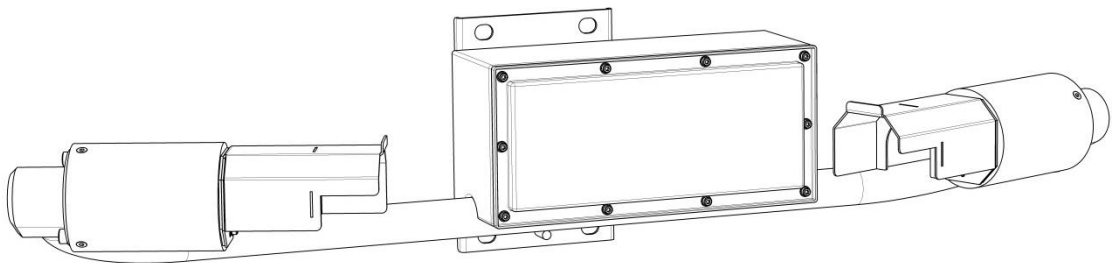

<b>SWS-200 – LW</b>	Visibility Precipitation type identification
---------------------	---

*This model has an extra backscatter receiver for:*

- Rain rate
- Snowfall rate
- Precipitation accumulation

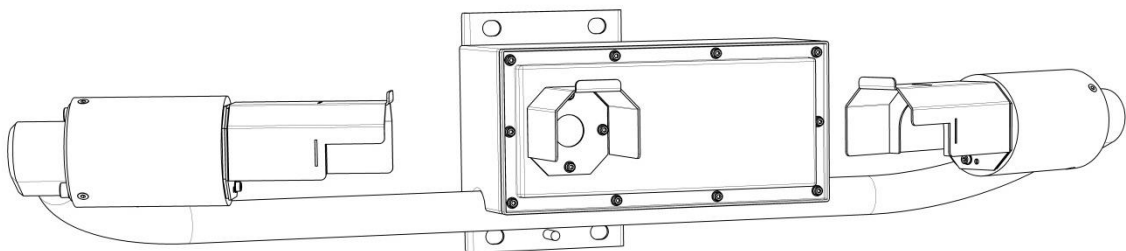

## 6.2 Instrument Components

Each sensor has been engineered and manufactured with high-reliability components to provide accurate measurements under all weather conditions. Its rugged aluminium powder-coated construction is intended to serve you in the severest of environmental conditions throughout the long life of the instrument. Both models are shipped fully assembled.

## 6.3 Accessories

### Calibration Kit

The calibration kit, containing a reference standard calibration plaque in a protective carrying case, is employed only at those times that the instrument calibration is being checked.

### Mains Adapter

A mains adapter is available if required.

### Cables

These may be ordered if required. The length must be specified at time of order.

### Calibration Arm mounting Bracket

This bracket is used when a field calibration of the sensor is required.

## 6.4 Sensor Features

The SWS sensors, including the SWS Lightweight sensor, are both visibility sensors and present weather sensors. They have the necessary optimum configuration for accurate measurement of visibility in the densest of fogs to very clear air conditions. They can detect the onset of precipitation as readily as a human observer and can measure the size and velocity of precipitation particles. Unique patented techniques utilising precipitation size/velocity distributions and backscatter / forward scatter ratios provide essentially error-free identification of the type of precipitation. False alarms and false identifications are kept to a minimum by the application of empirically derived algorithms sensitive to the characteristic of electronic noise and insects. Also unique is the sensor's capability for separating the contribution of extinction due to precipitation from the total atmospheric extinction coefficient, thus giving the sensor the capability to identify fog whenever it is simultaneously present during a precipitation episode.

In addition to its optimal and unique measurement capabilities, the SWS – LW sensor has a number of distinctive physical features:

**Compactness:**

The sensor is a single package, small in size and particularly light in weight. It can be readily installed by one person and can be used in portable or fixed installations.

**Low Power Consumption:**

The SWS – LW series of sensors have been designed specifically for low power applications. These include temporary installations away from mains power, where battery size and weight are of particular importance.

**Proven Software:**

The basic software incorporated into the sensor has evolved over a long period of time and has been tested and proven in hundreds of sensors.

**Ease of Maintenance and Calibration:**

Routine maintenance, including a check on calibrations, is performed in a matter of a few minutes. A re-calibration if required takes only slightly longer and is easily performed by one person.

## 6.5 Present Weather Definition

The term "Present Weather" is generally employed to define a large class of atmospheric phenomena that includes tornado activity, thunderstorm activity, precipitation, obstructions to vision, and "other atmospheric phenomena" such as aurora. For purposes of Automated Present Weather Sensors, the term "present weather" is restricted to those atmospheric phenomena that are local to the sensor. These phenomena include: (1) all forms of liquid and frozen precipitation; e.g., rain, drizzle, snow, snow pellets, snow grains, ice pellets (formerly sleet) and hail, and (2) those suspended particles that are classed as obstructions to vision; namely, mist, fog, haze, dust and smoke.

## 6.6 Automated Measurements

### 6.6.1 General

These sensors utilise microprocessor technology to perform automatic visibility, precipitation and temperature measurements. The standard version is DC powered, however, a mains converter is also available. Patented techniques are

employed to identify precipitation and to determine the presence of fog during episodes of precipitation.

### 6.6.2 Visibility Related Measurements

The measurement capabilities of the sensor are summarised in Table 6-1 Visibility Measurement Capabilities. Determination of visual range is based on measurements of the atmospheric extinction coefficient (EXCO). Note that EXCO includes the attenuating effects of both suspended particles and precipitating particles. Meteorological optical range (MOR) is determined by application of the standard relation,

$$\text{MOR} = 3.00/\text{EXCO}$$

Haze and fog are the two most common forms of obstructions to vision. In the absence of precipitation, the sensor determines the presence of haze or fog based on the MOR. If the MOR is less than 1 km, then fog (30) is indicated in the output message. If the MOR is between 1 and 10 km, then haze (04) is indicated in the output message. If MOR is greater than 10 km, no obstruction to vision is indicated.

#### Visibility Measurements

Function	Details
Meteorological Optical Range (MOR)	Selectable from the following options at time of order: 10m to 2Km 10m to 10Km 10m to 20Km 10m to 32Km 10m to 50Km 10m to 75Km Other ranges between 10m and 75Km by special request.
Accuracy	Better than 4.5% for MOR of 600m Better than 5% for MOR of 1500m Better than 5.1% for MOR of 2Km Better than 12.5% for MOR of 15Km Better than 20% for MOR of 30Km
Obstruction to vision	(1) Identifies Fog or Haze (Precipitation Absent). (2) Identifies Fog in Presence of Precipitation.

**Table 6-1 Visibility Measurement Capabilities**

**Precipitation/Obstruction to Vision Measurements**

Function	Details
(a) Liquid Precipitation: (Minimum Detection Limit)	0.00025 mm/min (0.00001 in/min). 0.015 mm/hr (0.00060 in/hr).
(b) Snow (H <sub>2</sub> O Equivalent): (Minimum Detection Limit)	0.000025 mm/min (0.000001 in/min). 0.0015 mm/hr (0.000060 in/hr).
Identification/Intensity: SWS-200 – LW only	Drizzle: Light/Moderate/Heavy. Rain: Light/Moderate/Heavy. Snow: Light/Moderate/Heavy. Hail
Precipitation rate:	Rain – Up to 500 mm/hr (20 in/hr). Snow – Rain Equivalent up to 500 mm/hr (20 in/hr).
Obstruction to vision:	Haze Fog

**Table 6-2 Precipitation Measurement Capabilities**

In the presence of precipitation, the sensor software measures the fraction of the atmospheric extinction coefficient due to precipitation and subtracts it from the total extinction coefficient to obtain a quantity we have named EXCO-EVENTS. If the value of EXCO-EVENTS is greater than 3.00, then fog is declared to be present in addition to the precipitation as an obstruction to vision.

### 6.6.3 Precipitation Measurements

The sensor identifies three forms of precipitation, namely drizzle, rain and snow. All forms of frozen precipitation are classified as snow. Detection of the onset of precipitation is extremely sensitive, being 0.00025 mm per minute for rain and approximately 0.000025 water equivalent mm per minute for snow.

Intensity of precipitation may be defined differently from one country to another. In both the United States and the United Kingdom, the intensity of precipitation is defined differently for drizzle and rain than for snow. For drizzle and rain, the intensity (slight, moderate and heavy) is based on the rate of fall of precipitation. For snow the intensity is based on visual range. In classifying precipitation intensity, the sensor utilises the precise definitions given by the UK CAA CAP 746 document, or in the US, the Federal Meteorological Handbook. These definitions are given in the tables below (Table 6-3 and Table 6-4).

*Note: If a sensor is intended for installation in a country where the definitions of precipitation intensity differ from the U.K. definitions, it is possible for the sensor to be produced with the appropriate definitions installed. BIRAL must be informed of this requirement at the time of order.*

#### UK Precipitation Definitions

##### Drizzle

Slight	A trace to 0.26mm/hour.
Moderate	0.26mm/hour to 1.0 mm/hour.
Heavy	More than 1.0 mm/hour.

##### Rain

Slight	A trace to 1.0 mm/hour.
Moderate	Greater than 1.0 mm/hour to 3.99 mm/hour.
Heavy	More than 3.99mm/hour.

##### Snow

Slight	Visibility greater than 800m
Moderate	Visibility between 400 and 800 meters.
Heavy	Visibility less than 400 meters.

**Table 6-3 UK Precipitation Intensity Definitions  
Based on CAA CAP 746 'Requirements for Meteorological Observations  
at Aerodromes'**

**US Precipitation Definitions**

**Drizzle**

Slight	A trace to 0.01 inches (0.3 mm)/hour.
Moderate	0.01 inches (0.3mm) to 0.02 inches (0.5 mm)/hour.
Heavy	More than 0.02 inches (0.5 mm)/hour.

**Rain**

Slight	A trace to 0.10 inches (2.5 mm)/hour.
Moderate	0.10 to 0.30 inches (2.6 to 7.6 mm)/hour.
Heavy	More than 0.30 inches (7.6 mm)/hour.

**Snow**

Slight	Visibility equal to or greater than 5/8 statute miles, 0.55 nautical miles, or 1,000 meters.
Moderate	Visibility between 1/4 and 5/8 statute miles, 0.2 to 0.55 nautical miles, or 400 to 1000 meters.
Heavy	Visibility equal to or less than 1/4 statute miles, 0.2 nautical miles, or 400 meters.

**Table 6-4 US Precipitation Intensity Definitions  
(Based on Federal Meteorological Handbook No. 1 Part B.1.)**

The following present weather codes are used on the SWS – LW series of sensors:

**Present Weather Codes – SWS-100 – LW**

Code	Description
XX	Not Ready (first 5 measurement periods from restart).
00	No Significant weather observed.
04	Haze or smoke.
30	Fog.
40	Indeterminate precipitation type.
50	Drizzle.
60	Rain.
70	Snow.

**Table 6-5 SWS-100 – LW WMO Codes**



**Present Weather Codes – SWS-200 – LW**

<b>Code</b>	<b>Description</b>
XX	Not Ready (first 5 measurement periods from restart).
00	No Significant weather observed.
04	Haze or smoke.
30	Fog.
40	Indeterminate precipitation type.
51	Light Drizzle.
52	Moderate Drizzle.
53	Heavy Drizzle.
61	Light Rain.
62	Moderate Rain.
63	Heavy Rain.
71	Light Snow.
72	Moderate Snow.
73	Heavy Snow.
89	Hail.

**Table 6-6 SWS-200 – LW WMO Codes**

## 6.7 Sensor Specifications

The specifications for the SWS lightweight sensor is summarised in the following pages.

### Visibility Measurements (MOR) and Precipitation Measurements

Function	Details
Measurement Range – MOR (Meteorological Optical Range)	Selectable from the following options at time of order: 10m to 2Km 10m to 10Km 10m to 20Km 10m to 32Km 10m to 50Km 10m to 75Km Other ranges between 10m and 75Km by special request.
Measures:	Visibility (MOR – Meteorological Optical Range), reductions caused by: fog, haze, smoke, sand, drizzle, rain, snow and general precipitation.
Measurement Accuracy	Better than 4.5% for MOR of 600m. Better than 5% for MOR of 1500m. Better than 5.1% for MOR of 2Km. Better than 12.5% for MOR of 15Km. Better than 20% for MOR of 30Km.
Measurement Time Constant	30 seconds.

### Stability of MOR Zero Setting

Function	Details
Ambient Temperature Effects	$\leq 0.02/\text{km}$ .
Long Term Drift	$\leq 0.02/\text{km}$ .

### Precipitation Measurements

Function	Details
Detection Threshold: Rain	0.015mm/hr (0.0006 in/hr).
Detection Threshold: Snow (H <sub>2</sub> O Equivalent)	0.0015mm/hr (0.00006 in/hr).
Rain Rate (Maximum)	~ 500mm/hr (20 in/hr).

## Maintenance

Function	Details
MTBF (Calculated)	52,500 hrs (6 years).
Typical Calibration Check Interval	6 months.
Typical Clean Windows Interval	3 months.
Remote Self-Test Monitoring	Included.

**Table 6-7 Sensor Specifications**

## 6.8 Instrument Characteristics

### Physical

Function	Details
Scattering Angle Coverage	39° to 51°.
Sample Volume	400 cm <sup>3</sup> .
Weight	2.7Kg. (3.2Kg with pole mounting kit)
Length	0.73 m.

### Light Source

Function	Details
Type	IRED.
Central Wavelength	0.85μm.
Bandwidth	0.04μm.
Lifetime	>10 years.
Modulation Frequency	2000 Hz.

### Detector

Function	Details
Type (Photovoltaic)	Silicon.
Response	Silicon.
Filter Bandwidth	0.08μm at 0.85μm.

**Temperature Sensor**

Function	Details
Type	Circuit mounted IC.
Range	-60°C to 100°C.

**Power Requirements**

Function	Details
Power Source (Voltage)	9V to 36V DC (24V typical).
Power Source (Wattage)	2.9 W.
Additional Power for: No-Dew Window Heaters	1.7W.
Additional Power for ALS-2 Option	1.2 W no window heater. 2 W with window heater.

**Environmental**

Function	Details
Operating Temperature Range	-40°C to +60°C.
Altitude	0 to 20,000 ft.
Precipitation	All weather.
Humidity	0 to 100%.
Protection Rating	IP66/67.
CE Certified	√
EMC Compliant	EN61326-1997,1998.2001.
RoHS and WEE Compliance	√

**Table 6-8 Instrument Characteristics**

## 6.9 Digital Communication Interface

### Communication Protocol

Function	Details
Interface Type	RS232C, (Full Duplex) .

### Communication Parameters:

Function	Details
Baud Rates	1200 Baud to 57K6 Baud, selectable.
Data Bits	8
Parity	None
Stop Bits	1
Flow Control	None
Message Termination	CR-LF
Message Checksum:	Selectable
Reporting Interval	Programmable: Response to poll, or Automatic at programmable intervals: e.g., 10 seconds to five minutes (1 minute typical).
Message Content:	<ul style="list-style-type: none"> <li>• Instrument Identification Number (Programmable).</li> <li>• Reporting Interval (seconds).</li> <li>• Meteorological Optical Range (Kilometres).</li> <li>• Precipitation Type.</li> <li>• Obstruction to Vision (Fog, Haze, None).</li> <li>• Precipitation Amount (One Minute Interval).</li> <li>• Temperature.</li> <li>• Remote Self-Test &amp; Monitoring Flags.</li> <li>• Date and time tags.</li> </ul>

**Table 6-9 Digital Communication Interface Specifications**

## 6.10 Sensor Remote Self-Test Capabilities

- Optical Source Power
- Transmitter Window Contamination
- Power Supply Voltages
- Non-Volatile Memory Checksum Test
- EPROM Check-Sum Test
- Restart Occurrence
- Sensor Sample Interrupt Verification
- RAM Read/Write Verification
- Register Read/Write Verification
- A/D Control Signal Test
- A/D Conversion Accuracy Check
- Input Voltage Check
- Forward-Scatter Background Illumination Level
- Back-Scatter Background Illumination Level

### 6.11 SWS Lightweight – external dimensions

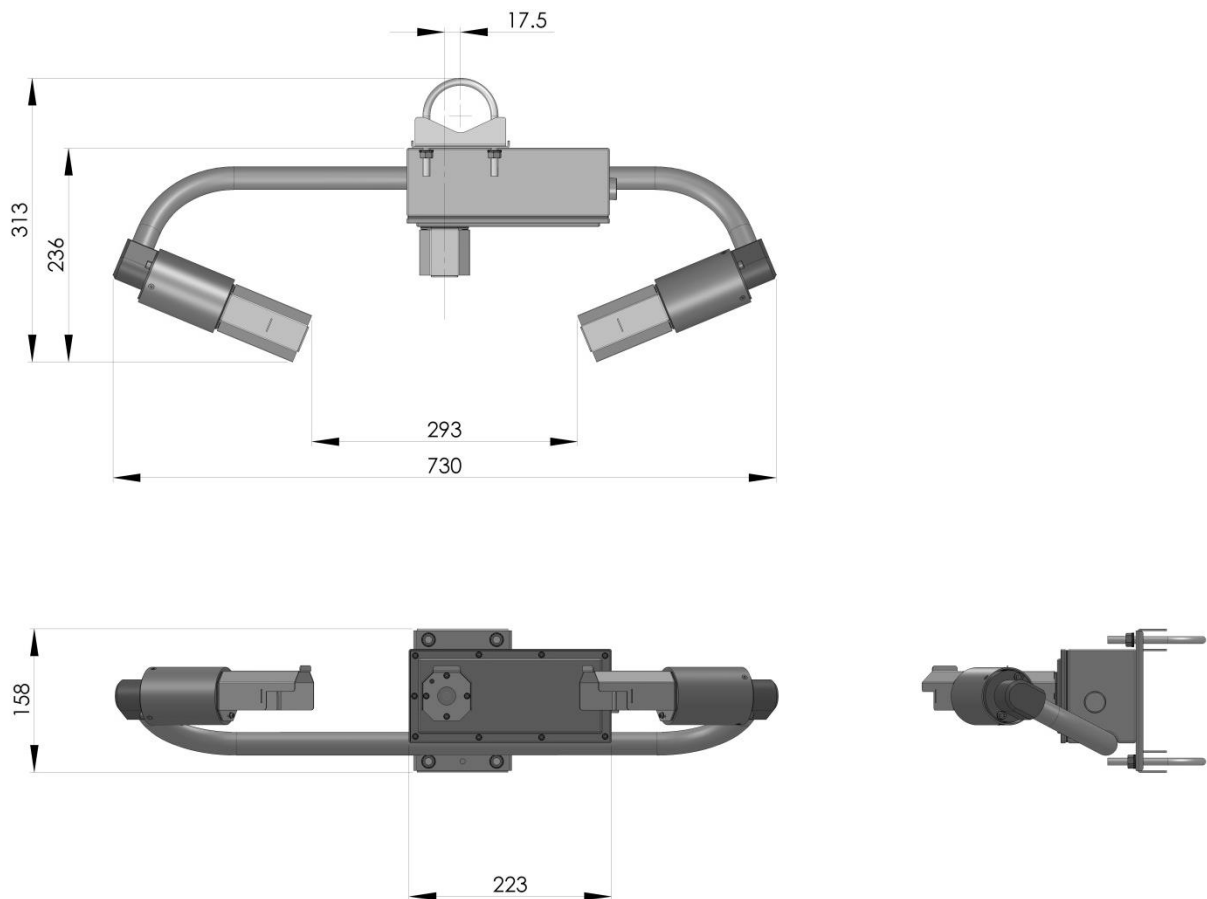

(Dimensions in mm)

**Figure 6-1 External Dimensions of SWS – LW Sensors**

## 7 INDEX

---

### A

ACCESSORIES	
Calibration Kit.....	49
Mains Adapter .....	49
Power and Signal Cables .....	49
AFTER SALES SUPPORT .....	VI
AMBIENT LIGHT SENSOR (ALS-2).....	4
Data Message Extension.....	28

---

### B

BACKSCATTER RECEIVER .....	38, 40, 49
BAUD RATE .....	6, 14, 20
<i>BIRAL SENSOR INTERFACE SOFTWARE</i> .....	1, 6, 20, 37, 41

---

### C

CABLES.....	3
Power and Signal Cables .....	2, 49
CALIBRATION.....	2, 18, 40
<i>Calibration Certificate</i> .....	6
Calibration Check.....	23, 41,
Calibration Kit.....	2, 49
Assembly.....	41
Precipitation Amount.....	47
Re-calibration .....	43
CE CERTIFICATION - SAFETY .....	VII
CHECKSUM .....	25, 27, 31
COMMANDS AND RESPONSES .....	29
Sensor Responses.....	33
TEST Command – Start / Stop Test Mode .....	32
COMMUNICATIONS CONFIGURATION.....	12
COMMUNICATIONS SPECIFICATION .....	59
CONFIGURATION OPTIONS .....	8
Automatic messages .....	13
Baud Rate.....	14
Baudrate.....	14
Checksum .....	11
Window Heaters .....	13
CONNECTIONS - ALS-2 .....	5
CONNECTOR .....	3
CONTACT DETAILS .....	VI

---

### D

DATA MESSAGE .....	24
Ambient Light Sensor (ALS-2) .....	28
Check Data Transmission .....	7
Example of Data Message .....	24, 26
DATE AND TIME STAMP.....	9



**E**

ELECTRICAL CONNECTIONS .....	3
Ambient Light Sensor (ALS-2) .....	4
Signal and Power .....	4
<b>ENVIRONMENTAL SPECIFICATION</b> .....	58
EQUIPMENT TEST .....	6

**H**

HEATERS .....	34
Window heaters (de-misters) .....	34

**I**

IDENTIFICATION NUMBER .....	24, 26, 29
INSTALLATION .....	15
Electrical Grounding .....	19
Height Above Ground .....	16
Mounting .....	17–19
Orientation .....	16–17
Siting Considerations .....	15
IP RATING .....	58

**M**

MAINS ADAPTER .....	2
MAINTENANCE .....	34
General Checks .....	34
Window Cleaning .....	34
Window Heaters .....	34
Self-Test Codes .....	35
User Confidence Checks .....	37
MOR Calibration Check .....	37
Receiver Background Brightness .....	38
Window Monitor Checks .....	37
MAINTENANCE SCHEDULE .....	57
METEOROLOGICAL OPTICAL RANGE .....	24, 25, 26, 40, 42, 44, 51, 56
MOUNTING .....	SEE INSTALLATION

**P**

PIN CONNECTIONS .....	4
Connections for RS232 .....	4
POWER CONNECTIONS .....	4
POWER REQUIREMENTS .....	58
PRECIPITATION AMOUNT CALIBRATION .....	47
PRECIPITATION MEASUREMENTS .....	52, 53
PRESENT WEATHER .....	50
Present weather codes in SWS-100 data message .....	25
Present weather codes in SWS-200 data message .....	26
PRESENT WEATHER CODES	
SWS-100 - LW .....	54
SWS-200 - LW .....	55
PRESENT WEATHER DEFINITION .....	50
PRODUCT OVERVIEW .....	48

**R**

REMOTE SELF-TEST & MONITORING	
Capabilities .....	60
Check .....	22
Data Message .....	7, 21
RESPONSES FROM SENSOR .....	33
To Command R? .....	31
To Command T? .....	32

**S**

SELF-TEST CODES .....	35
SENSOR DIMENSIONS .....	61
SENSOR ORIENTATION .....	16
SENSOR RESPONSES .....	33
SENSOR SPECIFICATION .....	56

**T**

TEST AND COMMISSIONING .....	20
TIME STAMP .....	9
TROUBLESHOOTING .....	20
Checking Data link .....	20
Checking Power Supply .....	20
Remote Self-Test Check .....	22
Self-Test Codes .....	35
Sensor Responses .....	33
Sensor Self-Test Capabilities .....	60

**U**

UK PRECIPITATION DEFINITIONS .....	53
US PRECIPITATION DEFINITIONS .....	54

**V**

VISIBILITY MEASUREMENTS .....	51, 56
-------------------------------	--------

**W**

WARRANTY .....	II, VII, 20
WINDOW CLEANING .....	35
WINDOW HEATERS .....	34

**Notes:**