

# User Manual

## VENTUS-X-, VENTUS-, V200A-UMB

### Ultrasonic Wind Sensors

*· a passion for precision · passion pour la précision · pasión por la precisión · passione per la precisione · a passion for precision*



[www.lufft.de](http://www.lufft.de)

 **Lufft**

## Contents

<b>Contents</b> .....	<b>2</b>
<b>1 Please Read Before Use</b> .....	<b>4</b>
1.1 Symbols Used.....	4
1.2 Safety Instructions .....	4
1.3 Designated Use .....	4
1.4 Incorrect Use .....	4
1.5 Warranty .....	4
1.6 Brand Names.....	4
<b>2 Scope of Supply</b> .....	<b>5</b>
<b>3 Order Number</b> .....	<b>5</b>
<b>4 Accessories</b> .....	<b>5</b>
<b>5 Additional Documents and Software</b> .....	<b>5</b>
<b>6 Equipment Description</b> .....	<b>6</b>
6.1 Wind .....	6
6.2 Virtual Temperature .....	7
6.3 Air Pressure.....	7
6.4 Heating .....	7
<b>7 Generation of Measurements</b> .....	<b>9</b>
7.1 Current Measurement (act).....	9
7.2 Minimum and Maximum Values (min and max) .....	9
7.3 Average Value (avg) .....	9
7.4 Vectorial Average Value (vct) .....	9
7.5 Wind Gust (WMO) .....	10
<b>8 Measurement Output</b> .....	<b>11</b>
8.1 Virtual Air Temperature.....	11
8.2 Heating Temperature.....	11
8.3 Air Pressure.....	11
8.4 Wind Speed .....	12
8.5 Wind Direction .....	12
8.6 Wind Measurement Quality .....	13
8.7 Status Information.....	13
<b>9 Installation</b> .....	<b>14</b>
9.1 Fastening.....	14
9.2 North Alignment.....	15
9.3 Selecting the Installation Location .....	16
<b>10 Connections</b> .....	<b>18</b>
10.1 Supply Voltage.....	19
10.2 RS485 Interface.....	19
10.3 Analog Interface Circuits.....	19
10.4 Control line.....	20
10.5 Connection to ISOCON-UMB (8160.UISO) .....	20
10.6 Use of surge protector (8379.USP-V) .....	21
10.7 SDI12 Connection.....	21
<b>11 Commissioning</b> .....	<b>22</b>
<b>12 Configuration and Test</b> .....	<b>23</b>
12.1 Luftt ConfigTool .....	23
12.2 Configuration .....	23
12.3 Value retrieval.....	28
<b>13 Firmware Update</b> .....	<b>31</b>
<b>14 Maintenance</b> .....	<b>31</b>

<b>15 Technical Data</b> .....	<b>32</b>
15.1 Measuring Range / Accuracy.....	33
15.2 Drawing .....	34
<b>16 EC Declaration of Conformity</b> .....	<b>35</b>
<b>17 Fault Description</b> .....	<b>36</b>
<b>18 Disposal</b> .....	<b>37</b>
18.1 Within the EC.....	37
18.2 Outside the EC .....	37
<b>19 Repair / Corrective Maintenance</b> .....	<b>37</b>
19.1 Technical Support.....	37
<b>20 Appendix</b> .....	<b>38</b>
20.1 Channel List Summary .....	38
20.2 Channel List Summary per TLS2002 FG3.....	39
20.3 Communication in Binary Protocol.....	40
20.4 Communication in ASCII Protocol.....	43
20.5 Communication in NMEA Protocol.....	45
20.6 Communication in SDI-12 Mode .....	55
20.7 Communication in Modbus Mode .....	65
<b>21 List of Figures</b> .....	<b>72</b>
<b>22 Keyword Index</b> .....	<b>73</b>

## 1 Please Read Before Use

### 1.1 Symbols Used



Important information concerning potential hazards to the user



Important information concerning the correct operation of the equipment

### 1.2 Safety Instructions



- Installation and commissioning must be carried out by suitably qualified specialist personnel only.
- Never take measurements on or touch live electrical parts.
- Pay attention to the technical data and storage and operating conditions.

### 1.3 Designated Use



- The equipment must only be operated within the range of the specified technical data.
- The equipment must only be used under the conditions and for the purposes for which it was designed.
- The safety and operation of the equipment can no longer be guaranteed if it is modified or adapted.

### 1.4 Incorrect Use



- If the equipment is installed incorrectly
- It may not function.
- It may be permanently damaged.
- Danger of injury may exist if the equipment is allowed to fall.



- If the equipment is not connected correctly
- It may not function.
- It may be permanently damaged.
- The possibility of an electrical shock may exist.

### 1.5 Warranty

The warranty period is 12 months from the date of delivery. The warranty is forfeited if the designated use is violated.

### 1.6 Brand Names

All brand names referred to are subject without limitation to the valid trademark and ownership rights of the respective owner.

## 2 Scope of Supply

- Equipment, sensor which essentially measures and returns the following quantities:
  - Wind direction
  - Wind speed
  - Wind gust
  - Virtual temperature
- Connection Plan

## 3 Order Number

8371.UMT	<b>Ventus</b> -UMB (metal)
8371.UMTX	<b>Ventus-X</b> UMB(metal)
8371.UA01	<b>V200A</b> -UMB (plastics)

## 4 Accessories

ISOCON-UMB	8160.UISO
Surge protection	8379.USP-V
Power supply unit	Recommended power supply unit: Phoenix contact TRIO-PS/1AC/24DC/10
Connector	8371.UST1 or Amphenol C091 31D008 101 2
Connector cable	Recommended cable: 8371.UK015     15m

## 5 Additional Documents and Software

You can download the following documents and software via the Internet at [www.lufft.com](http://www.lufft.com).

Operating Manual	• This document
UMB-Config-Tool	• Windows® software for testing, firmware updates and configuration of UMB devices
UMB Protocol	• Communication protocol for UMB devices
Firmware	• The current device firmware

## 6 Equipment Description

**Ventus** is a seawater-resistant wind meter which in addition to determining wind direction and wind speed is also capable of calculating virtual temperature.

**Ventus-X** is a **Ventus** variant. Beneath the standard heating, **Ventus-X** has got an additional heating, which is built within the ultrasonic heads. Therefore it particularly is suitable for winter operation.

**V200A** is a **Ventus** with a plastic housing. So it is a low-cost alternative to the conventional **Ventus**.

The equipment is connected by way of an 8 pole screw connector.

The measured values can be requested over a variety of interfaces:

- RS485 interface in half or full duplex
  - o UMB binary protocol
  - o UMB ASCII protocol
  - o NMEA protocol
  - o SDI-12 protocol
  - o Modbus-RTU and Modbus-ASCII protocols
- Analog data output of 2 adjustable channels with 4-20 mA, 0 – 10V or (channel 1 only) as frequency 2 – 2000Hz

During commissioning, configuration and measurement polling takes place using the Config-Tool.NET (Windows® PC software).

### 6.1 Wind

The measurement principle implemented for the **Ventus-UMB** is based on the measurement of the time of flight of ultrasonic pulses in air.

The measurement setup includes two measurement sections, arranged at an angle of 90°, with two ultrasonic transceivers each. The measurement sections are activated in turn and the time of flight of the ultrasonic pulses between the respective transmitter and receiver is measured. Within one measurement cycle each of the ultrasonic heads will work once as transmitter and once as receiver.

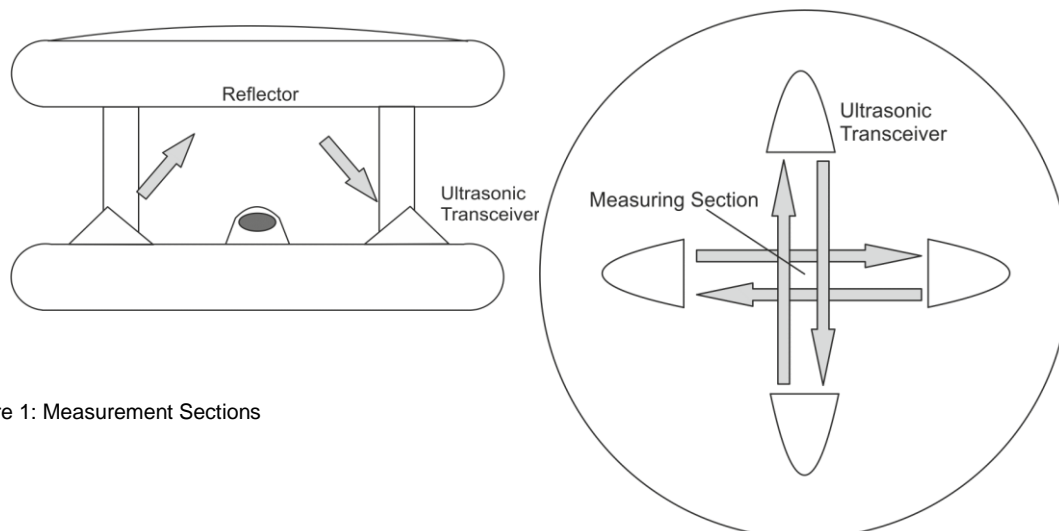

Figure 1: Measurement Sections

When measuring in still air all times of flight of one cycle will be equal on average.

If however an air flow is passing through the sensor, the ultrasonic pulse packet moving in the direction of the air flow will be accelerated, while the packet moving in opposite direction to the air flow will be decelerated. That means, the time of flight in the direction of wind will be shorter, while that in direction opposite to the wind direction will be longer.

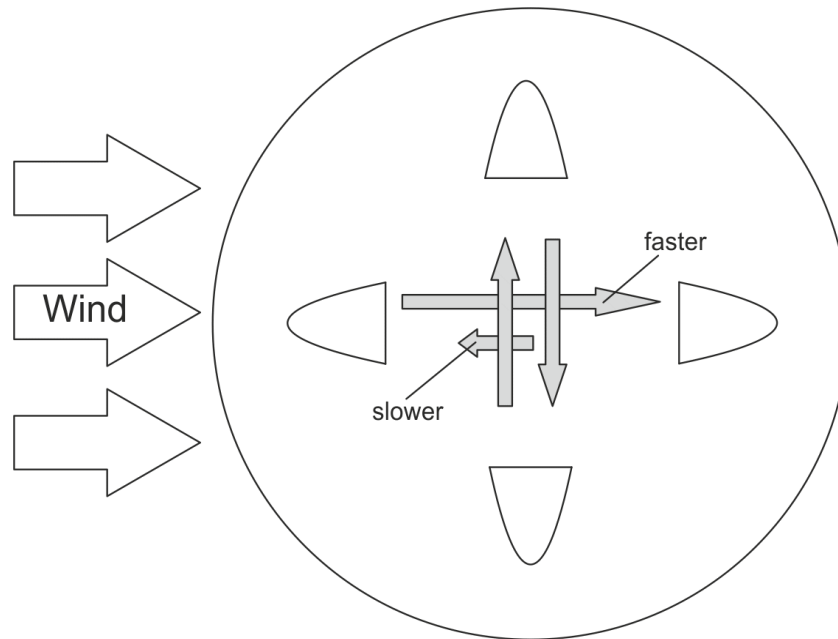

Figure 2 Influence of Wind on Time of Flight

The orthogonal arrangement of the measurement sections allows to evaluate the x and y components (resp. North-south and east-west components) of the air flow.

Basically the sonic velocity, and with it the time of flight of the ultrasonic pulse packets, will be influenced by air temperature and air humidity. The alternating measurement (north->south / south->north, west->east / east->west) compensates this influence.

The differences of the time of flight are averaged over a number of measurements, then the wind speed and wind direction is evaluated from the average.

The design of the sensor head protects, to a large extent, the measurement sections against rain and snow. The heating of the sensor prevents icing of the ultrasonic transceivers.

The aerodynamic design of the sensor head minimizes influences on the wind flow. Remaining deviations are evaluated during device calibration so that they are compensated during the calculation of wind speed and wind direction.

## 6.2 Virtual Temperature

Due to the physical relationship between the velocity of propagation of sound and the air temperature, the approximate ambient temperature can be determined with the aid of ultrasound sensors.

## 6.3 Air Pressure

The air pressure is measured by an integrated air pressure sensor

### 6.3.1 Air Density

Air density is calculated from the measured air pressure, virtual temperature and relative humidity. The *Ventus* doesn't measure relative humidity so a constant value, which can be adjusted through ConfigTool.NET, is applied. Factory setting is 75%.

## 6.4 Heating

For winter operation *Ventus* has got 2 heating elements (one element only on plastic version) to keep the sensor free of snow and ice. One element is in the cover (metal version only) and the other is built into the ultrasonic sensors.

To reduce the maximum operating current of the device, upper and lower heating can be switched alternately.

Separate measurement channels are available for the surveillance of the temperatures of upper and lower heater.

By default the heating is set in automatic mode and full capacity. This is the recommended heating mode of the sensor.

### 6.4.1 Heating mode

The heating of the device can be operated in 4 different modes:

- off: Heating always off
- auto: Automatic heating control<sup>1</sup>
  - The heating switches on when the housing temperature falls below +15°C (adjustable between 2°C and 20°C) and switches off at a housing temperature of >+20°C (set temperature +5°C) (**metal**)
  - The heating switches on when the housing temperature falls below +50°C (adjustable between 2°C and 70°C) and switches off at a housing temperature of >+55°C (set temperature +5°C) (**plastics**)
- testmode: The switch-on temperature is adjusted to +40°C; in this condition the heating switches on at room temperature (for test purposes only)
- ctrl high: Heating control is disabled when the control line is at the "high" level, else automatic
- ctrl low: Heating control is disabled when the control line is at the "low" level, else automatic

For configuration of the heating mode see chapter 0.

### 6.4.2 Heating capacity

The heating capacity can be set in accordance with the following modes:

- full: Full heating capacity (ca. 240W)<sup>1</sup>
- alternating: Alternating heating:
  - Cover plate alternating to base plate (ca. 100W or 150W alternating)
  - The next level of heating switches in if the pre-set temperature for the respective level is not reached within 4 minutes.
  - In this mode you only need a power supply with 140W.

For configuration of the heating capacity see chapter 0.

### 6.4.3 Heater Turn Off on Over / Under Voltage

If the heater turn off on over / under voltage is activated, the heating will be automatically switched off, if the supply voltage is outside of the surveillance window.

The lower threshold is ~20V, the upper threshold is ~28V.

For configuration of the turn-off-function see chapter 0.

---

<sup>1</sup> Factory setting



## 7 Generation of Measurements

### 7.1 Current Measurement (act)

In accordance with the specified sampling rate, the value of the last measurement is transmitted when the current measurement value is requested. Each measurement is stored in a circular buffer for the subsequent calculation of minimum, maximum and average values.

### 7.2 Minimum and Maximum Values (min and max)

When requesting the minimum and maximum values, the corresponding value is calculated - via the circular buffer at the interval specified in the configuration (1- 60 measurements) - and transmitted.

**Note:** In the case of wind direction, the minimum / maximum value indicates the direction at which the minimum / maximum wind speed was measured.

**Note:** On delivery, the interval for the calculation of minimum, maximum and average values is set at 60 measurements. If necessary, this can be adjusted to the particular requirements with the aid of the UMB-Config-Tool (see page 28).

### 7.3 Average Value (avg)

When requesting the average value, this is calculated - via the circular buffer at the interval specified in the configuration (1 - 60 measurements) - and transmitted. In this way moving averages can also be calculated.

### 7.4 Vectorial Average Value (vct)

In the specific case of wind measurement, measurements are calculated vectorially. To this end, the average values of the vectors are generated internally. Hence the value (wind speed) and angle (wind direction) of the vector are calculated.



## 7.5 Wind Gust (WMO)

Wind gust is evaluated conforming with the WMO recommendations (\*) as highest 3sec average of the wind speed within the last 10min. The 3sec averages are built from the 250ms measurement values. The output values wind gust speed and wind gust direction are updated once per minute.

The timing setting of 3sec/10min is fixed and is not influenced by the general measurement interval settings.

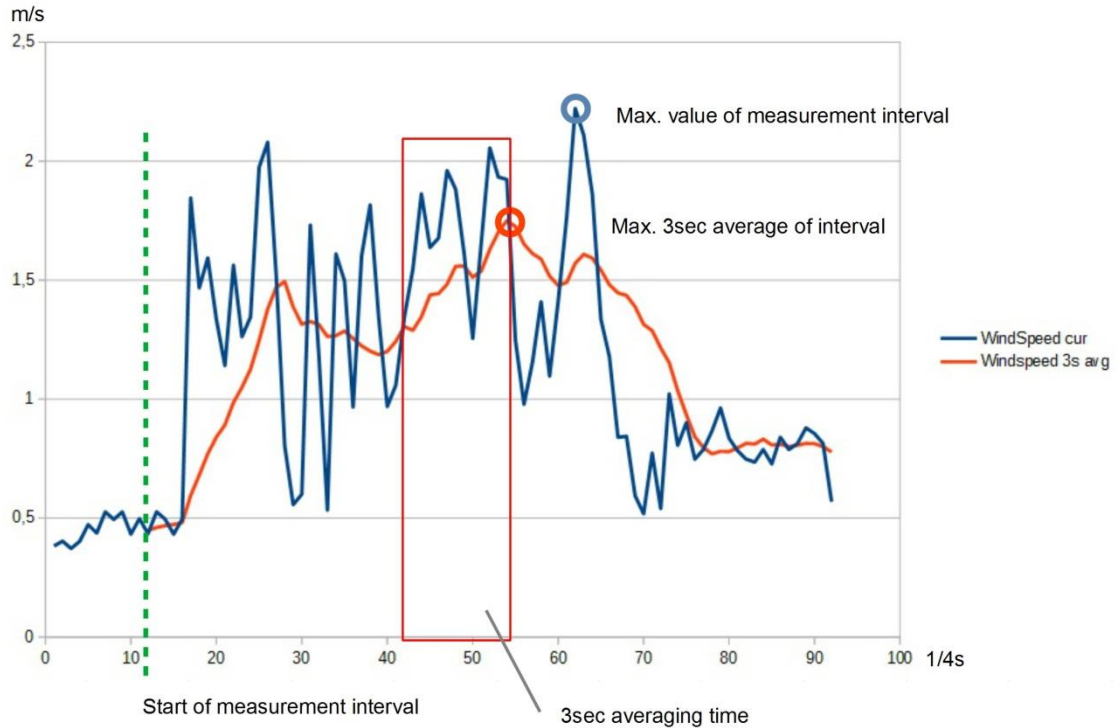

Figure 3 Example of Wind Gust Evaluation

(\*) WMO: Guide to Meteorological Instruments and Methods of Observation (WMO-No.8), 2014/2017. Ch. 5.8.3, S. 176

## 8 Measurement Output

The factory default setting for the transmission of measurements is UMB binary protocol.

You can find an example of a measurement request for the various protocols and a complete summary of the list of channels in the Appendix.

Values outside the measuring range as well as invalid measured values are identified by status values. An overview of the errors in the UMB protocol can be found in the manual <https://www.lufft.com/download/manual-lufft-umb-protocol-en/> in section 3.6. For status values in SDI-12 protocols refer to section 20.6.7 and for Modbus protocols to Table 2.

### 8.1 Virtual Air Temperature

Sampling rate 1 – 10 seconds  
 Generation of average value 1 – 60 measurements  
 Units °C; °F

Request channels:



UMB Channel				Measurement Variable	Measuring Range		
act	min	max	avg		min	max	unit
100	120	140	160	Virtual air temperature	-50.0	70.0	°C
105	125	145	165	Virtual air temperature	-58.0	158.0	°F

**Note:** In order to transmit the current measurement value the second measurement values are averaged over the sampling rate.

### 8.2 Heating Temperature

Sampling rate 1 – 10 seconds  
 Generation of average value 1 – 60 measurements  
 Units °C; °F

Request channels:

UMB Channel				Measurement Variable	Measuring Range		
act	min	max	avg		min	max	unit
112				Heating temperature top	-50.0	150.0	°C
113				Heating temperature bottom	-50.0	150.0	°C
117				Heating temperature top	-58.0	302.0	°F
118				Heating temperature bottom	-58.0	302.0	°F

### 8.3 Air Pressure

Sampling rate 10 seconds  
 Generation of average value 20 measurements  
 Units hPa

Request channels:



UMB Channel				Measurement Variable	Measuring Range		
act	min	max	avg		min	max	unit
300	320	340	360	Absolute air pressure	300.0	1200.0	hPa
305	325	345	365	Relative air pressure	300.0	1200.0	hPa

**Note:** For pressure measurement a hardware version equal or greater than 3.0 and a software version equal or greater than 1.6 is necessary!

#### 8.3.1 Air Density

Sampling rate 10 seconds  
 Unit kg/m<sup>3</sup>

Request channel:



UMB Channel				Measurement Variable	Measuring Range		
act	min	max	avg		min	max	Unit
310				Air Density	0.0	3.0	kg/m <sup>3</sup>

**Note:** Relative humidity is required for the calculation of air density. As Ventus-UMB does not include a humidity sensor, an adjustable standard value is applied. With UMB-ConfigTool.NET

this value can be adapted to the conditions at the location of installation (see Chapter 12.2.8) .  
Factory setting is 75% rel. humidity.

#### 8.4 Wind Speed

Sampling rate 250ms; 1 – 10 seconds  
 Generation of average value 1 – 60 measurements  
 Generation of maximum value 1 – 60 measurements based on the internal second measurement values  
 Units m/s; km/h; mph; kts  
 Response threshold 0.1 m/s (metal) or 0.3 m/s (plastics)  
 Request channels:

UMB Channel					Measurement Variable	Measuring Range		
act	min	max	avg	vct		min	max	unit
400	420	440	460	480	Wind Speed	0	90.0	m/s
405	425	445	465	485	Wind Speed	0	324.0	km/h
410	430	450	470	490	Wind Speed	0	201.3	mph
415	435	455	475	495	Wind Speed	0	174.9	kts

**Note:** In order to transmit the current measurement value the second measurement values are averaged over the sampling rate.

#### 8.4.1 Wind Gust Speed (WMO Specification)

Sampling Rate 250ms, update rate 1min  
 Generation of Value Highest 3sec average of the last 10min  
 Request channels:

UMB Channel					Measurement Variable	Measuring Range		
act	min	max	avg	vct		min	max	unit
443					Wind Gust Speed	0	90.0	m/s
448					Wind Gust Speed	0	324.0	km/h
453					Wind Gust Speed	0	201.3	mph
458					Wind Gust Speed	0	174.9	kts

**Note:** With extended sampling rates (50ms / 100ms) the evaluation of wind gust speed and wind gust direction is deactivated. The channels will show status "channel off" (0x36).

#### 8.5 Wind Direction

Sampling rate 250ms; 1 – 10 seconds  
 Generation of average value 1 – 60 measurements  
 Generation of maximum value 1 – 60 measurements based on the internal second measurement values Unit °  
 Response threshold 0.1 m/s (metal) or 0.3 m/s (plastics)  
 Request channels:

UMB Channel					Measurement Variable	Measuring Range		
act	min	max	avg	vct		min	max	unit
500	520	540		580	Wind Direction	0	359.9	°
543					Wind Gust Direction	0	359.9	°

**Note:** In order to transmit the current measurement value the second measurement values are averaged over the sampling rate.

The minimum / maximum wind direction indicates the direction at which the minimum / maximum wind speed was measured.

The wind gust direction is the vector average of the direction measured during the highest 3sec speed average of the last 10min.

## 8.6 Wind Measurement Quality

Sampling rate 250ms; 1 – 10 seconds

Units %

Request channels:

UMB Channel					Measurement Variable	Measuring Range		
act	min	max	avg	vct		min	max	unit
805					Wind measurement quality	0	100	%



**Note:** The value is updated every 0.25 – 10 seconds and transmits the minimum wind quality of the last measurement.

This value allows the user to assess how well the measurement system is functioning in the respective ambient conditions. In normal circumstances the value is 90 - 100%. Values up to 50% do not represent a general problem. If the value falls towards zero the measuring system is reaching its limits.

If during critical ambient conditions the system is no longer able to conduct reliable measurements, error value 55h (85d) is transmitted for wind speed and wind direction (device unable to execute valid measurement due to ambient conditions).

## 8.7 Status Information

UMB Channel					Measurement Variable	Measuring Range
act	min	max	avg	vct		
4006					Status supply voltage, upper threshold (~ 28V)	0 : Voltage <= 28V 1: Voltage > 28V
4007					Status supply voltage, lower threshold (~ 20V)	0 : Voltage >= 20V 1: Voltage < 20V
4997					Status lower heating	0: Heating off 1: Heating on
4998					Status upper heating	0: Heating off 1: Heating on

## 9 Installation

The sensor bracket is designed to be installed on the top of a mast with a diameter of 50mm or 2".

The following tools are required for the installation:

- Hexagon socket 4.0
- Compass for aligning *Ventus* to the North

### 9.1 Fastening

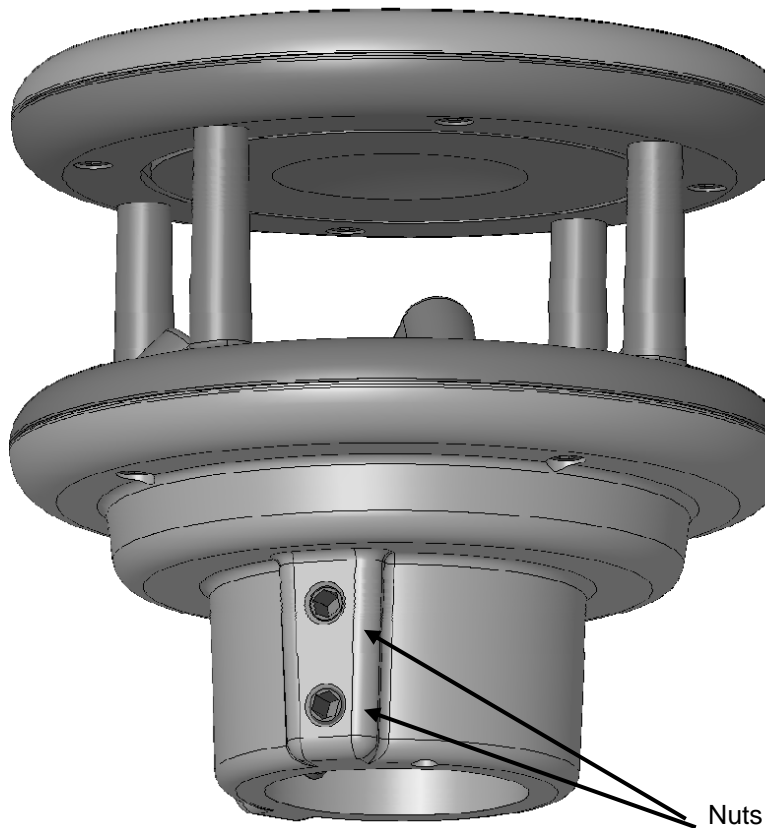
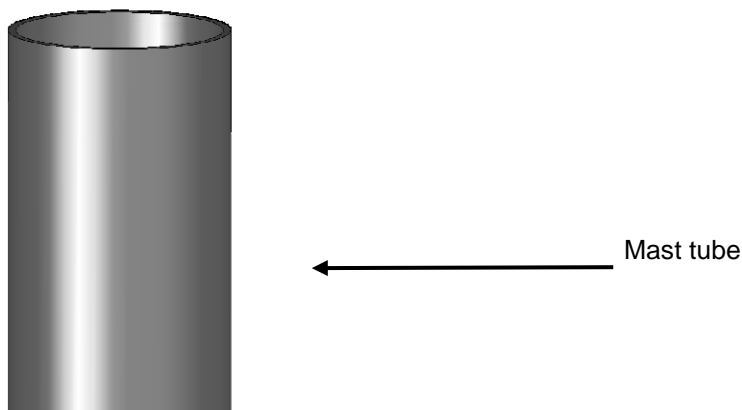

Figure 4 Fastening to the Mast



- Loosen nuts
- Push the sensor onto the top of the mast from above
- Align the sensor to the North
- Tighten both nuts evenly and secure with locking varnish

## 9.2 North Alignment

In order for the wind direction to display correctly, the sensor must be aligned to the North. The sensor has a number of directional arrows and a North drill hole for this purpose.



Figure 5 North Markings

### Procedure:

- If the sensor is already installed, first loosen both nuts evenly until you can turn the sensor easily
- Using the compass, identify the North and fix a point of reference on the horizon
- Position the sensor in such a way that the South and North sensors are in alignment with the fixed point of reference in the North
- Tighten both nuts evenly

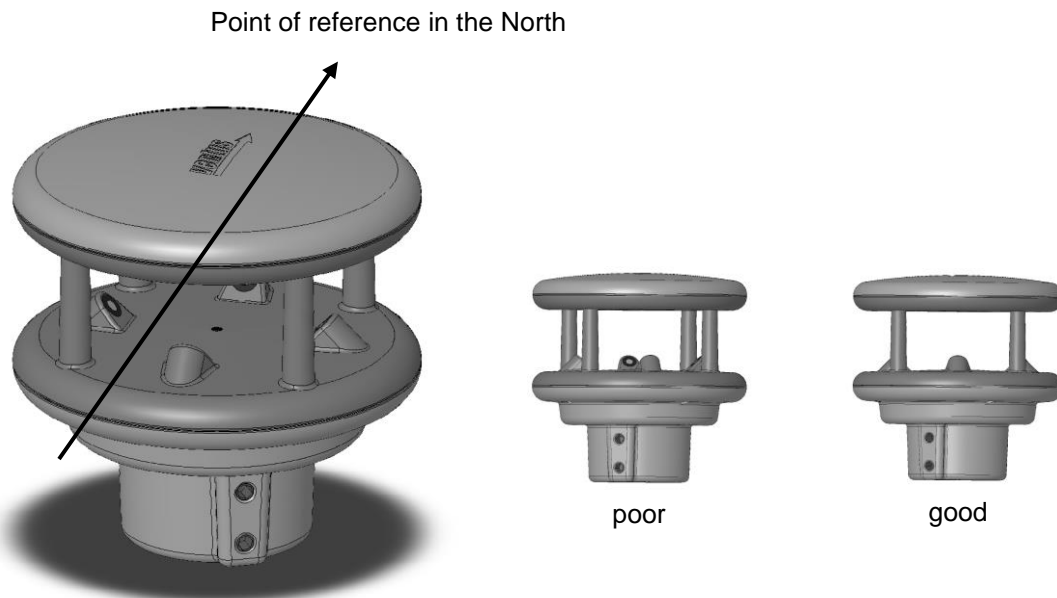

Figure 6 Alignment to North



**Note:** As the magnetic North Pole indicated by the compass differs from the Geographic North Pole, account must be taken of the declination (variation) at the location when aligning the sensor.

Depending on the location, the variation can be more than 15° (in North America for example). In Central Europe the variation can be largely ignored at present (< 3°). You can find further helpful information on this subject on the Internet.

### 9.3 Selecting the Installation Location

In order to guarantee long service life and correct equipment operation, please pay attention to the following points when selecting the installation location.

#### 9.3.1 General Instructions

- Stable subsurface for installing the mast
- Free access to the equipment for maintenance works
- Reliable power supply for permanent operation
- Good network coverage when transmitting over a mobile communications network



**Note:** The computed measurements specifically apply to the equipment location only. No conclusions can be drawn with regard to the wider environment or a complete road section.

#### ATTENTION:

- Only approved and tested appliances (conductors, risers etc.) should be used to install the device on the mast.
- All relevant regulations for working at this height must be observed.
- The mast must be sized and anchored appropriately.
- The mast must be **earthed** in accordance with regulations.
- The corresponding safety regulations for working at road side and in the vicinity of the road carriageway must be observed.



If the equipment is installed incorrectly

- It may not function.
- It may be permanently damaged.
- Danger of injury may exist if the equipment is allowed to fall.



#### 9.3.2 Installation of Ventus

- Installation at the top of the mast
- Installation height at least 2m above the ground
- Free field around the sensor



**Note:** Buildings, bridges, embankments and trees may corrupt the wind measurement. Equally, passing traffic may cause gusts which may influence the wind measurement.



**9.3.3 Installation Sketch**

Figure 7 Installations Sketch

## 10 Connections

There is an 8 pole screw connector on the underside of the equipment. This serves to connect the supply voltage and interfaces by a connection cable.

Equipment connector:

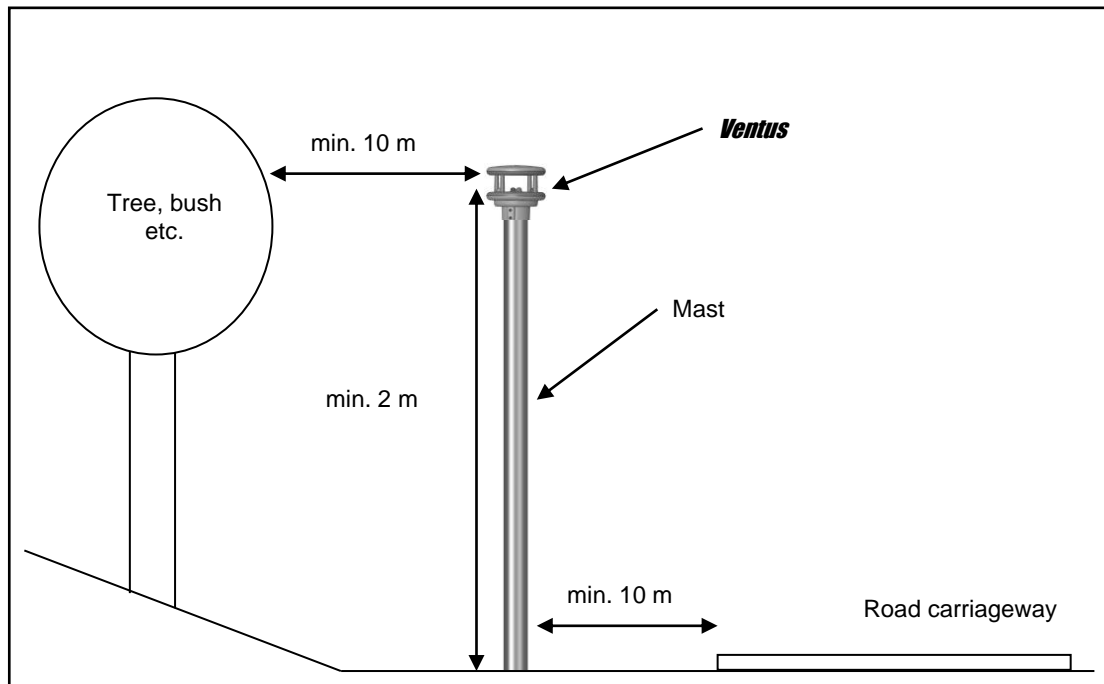
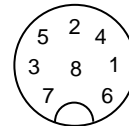

View on cable socket solder connection

Figure 8 Connections

Pin assignment full duplex:

1	Y	Serial interface RXD-	pink
2	B	Serial interface TXD-	yellow
3		Control connection	red
4	Z	Serial interface RXD+	grey
5	A	Serial interface TXD+	green
6		Analog ground	blue
7		Supply voltage -	white
8		Supply voltage +	brown

Pin assignment half duplex/analog interface:

1		Analog interface A	pink
2	B	Serial interface RXD/TXD-	yellow
3		Control connection	red
4		Analog interface B	grey
5	A	Serial interface RXD/TXD+	green
6		Analog ground	blue
7		Supply voltage -	white
8		Supply voltage +	brown

Pin assignment SDI-12 interface:

1		-	pink
2		SDI-12 Data	yellow
3		SDI-12 activation	red
4		-	grey
5			green
6		SDI-12 GND and SDI-12 activation	blue
7		Supply voltage -	white
8		Supply voltage +	brown

(for SDI12 connection please always follow the detailed notes in Chap. 10.7)

**Installation requirements**



The cable routing from the power supply unit to the **Ventus** must be designed according to the SELV mode, i.e. the ground of the power supply unit and the ground connection of the power supply unit shall not be connected!

It is recommended to use the Lufft connection cable 8371.UK015. The connecting cable should be shortened to the minimum length necessary to minimize the voltage drop on the cable and thus enable the maximum heating power. When using the 15m long 8371.UK015 cable, there is still a maximum of 150W heating power available on the Ventus due to the voltage drop on the cable.

Cable lengths greater than 15 m must always be adapted to a larger cable cross-section in the supply wires (2.5 mm<sup>2</sup> - 4 mm<sup>2</sup> corresponds to approx. 20 m - 50 m cable length).



**The *Ventus* will be earthed through the screws with the earthed mast. The connection cable screen must NOT be laid to ground in the control panel for *Ventus*!**



**For the V200A the connection cable screen MUST be laid to ground in the control panel!**

If the equipment is not connected correctly

- It may not function
- It may be permanently damaged
- The possibility of an electrical shock may exist under certain circumstances

**10.1 Supply Voltage**

The supply voltage for **Ventus** is 24V DC ± 10%. The power supply unit used must be approved for operation with equipment of protection class III (SELV).

**10.2 RS485 Interface**

The equipment has an electrically isolated RS485 interface for configuration, measurement polling and the firmware update.

The RS485 interface is designed as optionally half or full duplex, 2 or 4 wire connection.

The following operating restrictions exist depending on the half or full duplex operation setting:

Full duplex	Half duplex <sup>1</sup>
Autonomous telegram transmission is possible	No autonomous telegram transmission possible
Transmission of values via current output is not possible	Transmission of values via current output is possible
Heating control via control pin is possible	Heating control via control pin is possible
Triggering of NMEA telegram transmission over Control-PIN is possible	Triggering of NMEA telegram transmission over Control-PIN is not possible
SDI-12 Mode not possible	SDI-12 Mode possible
Firmware update not possible	Firmware update possible

Restrictions in full and half duplex operation

See page 32 for technical details.

**10.3 Analog Interface Circuits**

2 analog interface circuits are provided for analog data transmission. Both are updated every 250ms.

Interface A can be configured for 0 or 4-20mA current output, 0 or 2-10V voltage output as well as for frequency output in the range from 2 – 2000Hz (with adjustable voltage level up to 10V)

<sup>1</sup> Factory setting



**Note:** For the use of the analog outputs the serial communication protocol must be set to UMB binary!

Interface B can be configured for 0 or 4-20mA current output and 0 or 2-10V voltage output. The channels to be transmitted by way of these interfaces can be adjusted with the aid of the UMB-Config-Tool. The default values are Channels 400 (current wind speed in m/s (A)) and 500 (current wind direction (B)).

The scaling of the outputs is also adjustable.

The maximum load on the current output is 300  $\Omega$ .

#### 10.4 Control line

The respective function can be adjusted using the UMB-Config-Tool. The control line can be used either to control heating in half or full duplex operation or to control telegram transmission in full duplex mode. In this case control is possible by means of a volt-free switching contact.

Control line at “high” when control and analog ground are not connected.

Control line at “low” when control and analog ground are short-circuited.

For activation of the SDI-12 mode the control line is to be set to “low”, i.e. control input and analog ground are to be connected.

##### 10.4.1 Control line disabled

The control line level has no effect.

##### 10.4.2 Heating control

- Heating is disabled when control line is at “high” level, otherwise automatic
- Heating is disabled when control line is at “low” level, otherwise automatic

##### 10.4.3 Control of telegram transmission in NMEA protocol

- Telegram transmission triggered on rising edge of control voltage
- Telegram transmission triggered on falling edge of control voltage
- Telegram transmission while control voltage is “high”
- Telegram transmission while control voltage is “low”

#### 10.5 Connection to ISOCON-UMB (8160.UISO)

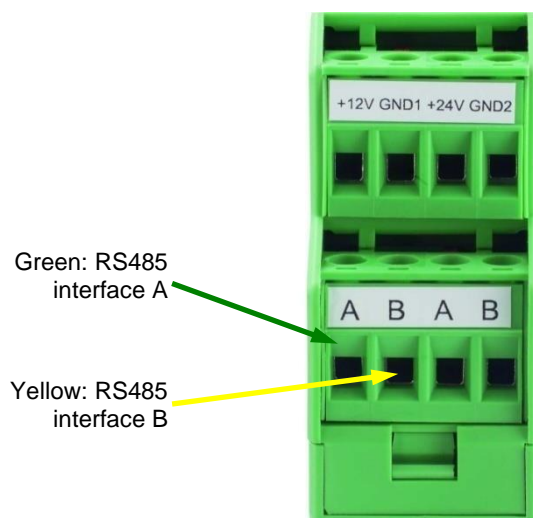

Figure 9 Connection to ISOCON-UMB



**Warning:** The power supply is **not** connected to the ISOCON-UMB but is wired directly to the power supply unit, as the ISOCON-UMB is not designed for the 240W heating duty of the **Ventus** device.

Please pay attention to the ISOCON-UMB operating manual when building the equipment.

**10.6 Use of surge protector (8379.USP-V)**

Please refer to the connection example in the operating manual when using the surge protector (Order no.: 8379.USP).

**10.7 SDI12 Connection**

When connecting the sensor to a SDI12 logger two options for the power supply are available:

- Power supply through the SDI12 12V line
- Power supply from a separate source, isolated from the logger

The must be adapted to the individual power supply option

**Supply through the SDI12 BUS**

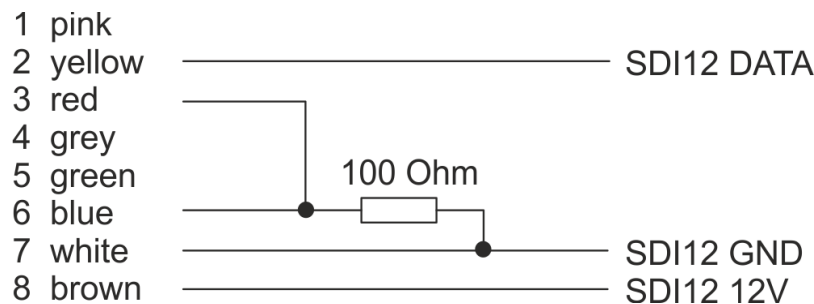

**Note:** when using this connection option the internal isolation of the **Ventus** power supply will be bypassed.



**Note:** the resistor must be mounted at the end of the cable which it is connected to the logger. Otherwise the voltage drop over the cable may cause potential differences which prohibit communication.

**Supply from separate source**

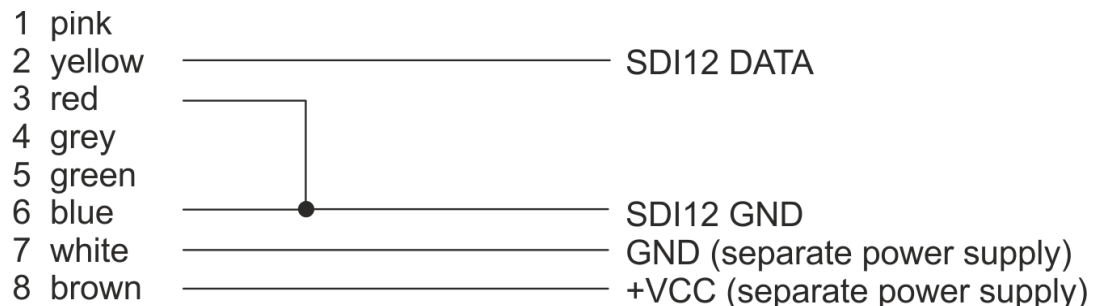

## 11 Commissioning

After the equipment has been installed and connected correctly, the sensor begins autonomously to take measurements. A Windows® PC with serial interface, UMB-Config-Tool software and interface cable (SUB-D 9 pole; jack - socket; 1:1) are required for configuration and test purposes.

Attention must be paid to the following points:

- Check for correct equipment operation on site by carrying out a measurement with the aid of the UMB-Config-Tool (see page 28).
- The device must be aligned to the North in order to ensure correct wind measurement (see page 15).
- If several **Ventus** devices are operated on a UMB network, a unique device ID must be assigned to each device (see page 24).

There is no protective cover to remove on the sensor itself.

## 12 Configuration and Test

### 12.1 Lufft ConfigTool

For configuring and testing the **Ventus** Lufft provides the proprietary software UMB-ConfigTool.Net. This program can also be used to update the firmware of the **Ventus**.

You will find the PC version on the Lufft homepage: <https://www.lufft.com/resources/>

Download the software UMB-ConfigTool.Net and install it on your computer. Use the online help of the software in order to get familiar with the program in general.

The coming chapters only deal with aspects that apply specifically to **Ventus**.



**Notes:** During configuration and test all other interrogating devices such as modems / LCOM etc. have to be disconnected from the network.

**Note:** The communication settings of the UMB-ConfigTool.Net have to be the same as in the device.

**Ventus** default settings are: baud rate: 19200, data format 8N1.

### 12.2 Configuration

#### 12.2.1 Sensor selection

Add a new device to your workspace by pressing „+“ on your keyboard. You will enter the menu for configuring a new device, see Figure 10.

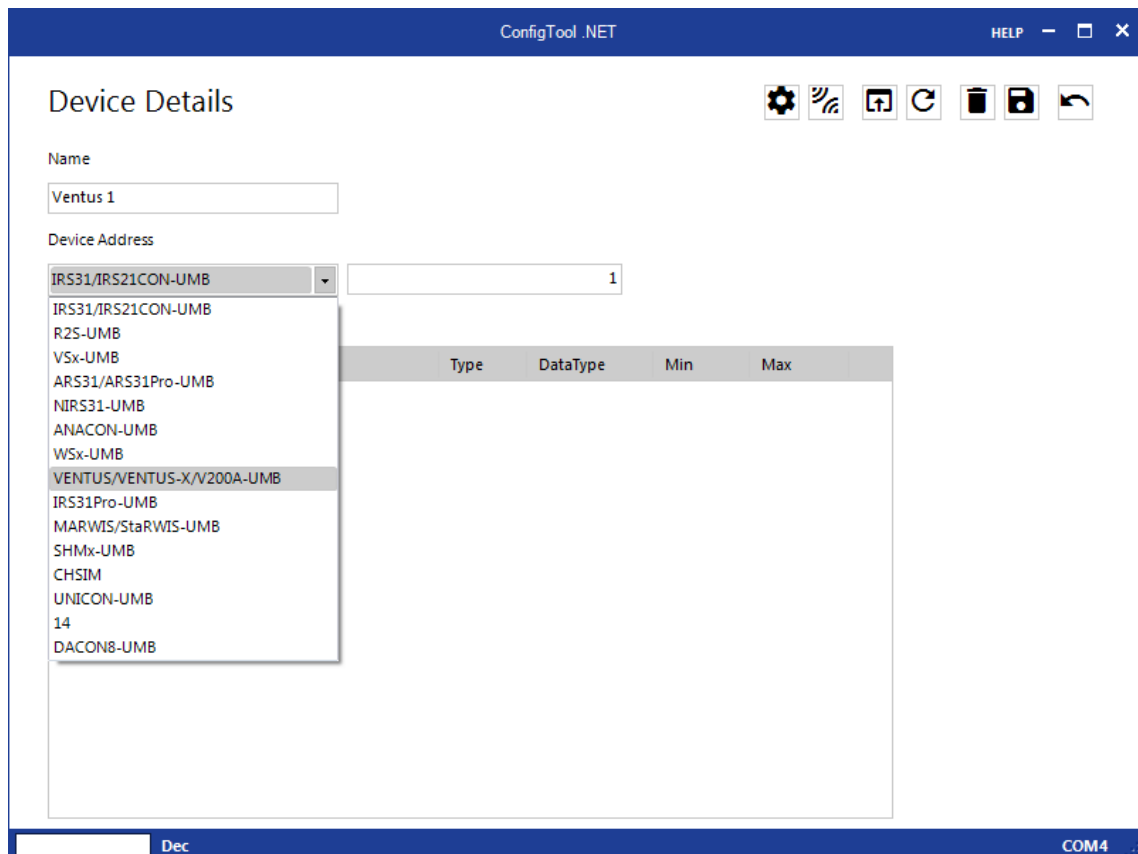

Figure 10: Sensor selection

- Give the device a name of your choice. You will be able to change it later at any time.
- Select „ Ventus / Ventus-X / V200A-UMB“ in the device selection list
- Enter the device address (device ID) into the field next to the device selection list  
This is the address over which the UMB-ConfigTool.Net will later communicate with the device.
- Save your entries. You will get back to the overview of your workspace.
- Select the sensor that you have just set up.



**Note:** The default address on delivery is 1. For the first commissioning therefore device address 1 has to be selected. If the device address is changed in the configuration settings, the address that is saved in the UMB-ConfigTool.Net has to be changed accordingly.



**Note:** If several **Ventus** are used in one UMB network, each one must have its unique ID. It makes sense to start with 1 and count upwards.

### 12.2.2 Device settings

All **Ventus** parameters are shown in the device settings. Unchangeable settings have a grey background, see Figure 11.

General device description	
Running number	176
Date of production	1116
Project number	901
BOM rev.	10
Schematic rev.	5
HW rev.	5
SW rev.	31
Configuration rev.	17
Device rev.	29
Calibration rev.	13
Device type	0
Device identification	
Class-ID	8
Device-ID	1
Device name	VENTUS-V200A-UMB
Device description	ultrasonic metal wind sensor VENTUS-...
Device parameters	
Baudrate	19200 Bd
Protocol	UMB BINARY
Protocol timeout [min]	10
Device start counter	0
SW reset counter	0
Ventus Subtype	0
WD reset counter	0
Communication Parameters	

Figure 11: Device settings

### 12.2.3 Device identification

Device ID: Device ID  
default setting 1; to further devices assigne IDs in ascending order

Device description: For identifying the devices a description like the location can be entered

### 12.2.4 Device parameters

Baudrate: Transfer rate of the RS485 interface  
default setting 19200 Baud; DO NOT change if used with ISOCON-UMB.



Protocol:	Communication protocol of the sensor (Binary, ASCII, NMEA, SDI-12, Modbus-RTU, Modbus-ASCII) default setting: UMB Binar
Protocol timeout:	if the communication protocol is changed temporarily this is the interval in minutes after which it is switched back to the configured protocol (without function at present)

### 12.2.5 Communication parameters

Communication Parameters	
Full-duplex	off
MODBUS: Parity	8N1
MODBUS: Altitude [m]	0
SDI-12: Unit	metric
NMEA: Device ID: First letter	W
NMEA: Device ID: Second letter	I
NMEA: Control Pin	Heating
NMEA: Automatic telegram transmission...	off
NMEA: Response delay [ms]	0
NMEA: Output rate [ms]	10000
NMEA: Output scale	ms
NMEA: mode	Standard
Heating Parameters	

Figure 12: Communication Parameters

Double directed:	on at full duplex, off at half duplex default: off
Parity:	number of data bits, parity, number of stop bits default: 8N1
MODBUS: Altitude:	altitude for MODBUS protocol default: 0m
SDI-12: Unit:	Selection between metric or US units. default: metric
NMEA: Device ID:	First two letters in the NMEA telegram The first two characters of the NMEA telegram identifier which determine the device type can be configured. If the second character is defined as „#0“ it is suppressed so that the ID consists of only one characters. default: WI
NMEA: Control Pin:	The control line can be used either for controlling the heating or for controlling the NMEA output. default: heating
NMEA: Automatic telegram transmission and format:	Defines if and in which format an automatic NMEA output shall be carried out default: off
NMEA: Response delay:	Delay time of the NMEA response telegram in ms default: 0ms
NMEA: Output rate:	Interval for automated NMEA output in ms default: 10000ms
NMEA: Output scale:	Unit of the wind value in the NMEA telegram (m/s, km/h, Meilen/h, knots) default: m/s
NMEA: mode:	Selection standard or variant, denominates variants of implementation

### 12.2.6 Heating Parameters

Heating Parameters	
Setpoint temperature [°C]	15
Heater mode	auto
Capacity	full
Disable if overvoltage	yes
Disable if undervoltage	no

Figure 13: Heating Parameters

- Setpoint temperature: Temperature to which the **Ventus** is heated  
default: 15°C
- Heater mode: off: heating is off  
auto: automated control to setpoint temperature  
testmode: **Ventus** is heated to test setpoint temperature  
ctrl high: heating off if control line on high,  
otherwise: automatic control  
ctrl low: heating off if control line on low  
otherwise: automatic control  
default: auto
- Capacity: full: full heating power  
alternating: upper plate and lower plate alternatingly  
default: full
- Disable if overvoltage: the heating is disabled if overvoltage (28V) is detected  
default: yes
- Disable if undervoltage: the heating is disabled if undervoltage (20V) is detected  
default: no

### 12.2.7 Wind Parameters

Wind Parameters	
Min. speed	0.1
Counts of measurements	60
Direction offset	0
Measurement rate [s]	10
Pressure Parameters	
Pressure offset	0
Counts of measurements	10
Relative air humidity [%]	75

Figure 14: Wind Parameters

- Min. speed: starting speed of the wind sensor in m/s  
default: 0,1m/s
- Counts of measurements: Number of measured values used for determining the statistical values of average, minum value and maximum value  
default: 60
- Direction Offset: Correction of the wind direction  
It is possible to have an offset added to the measured wind direction, in order to convert e.g. 0° (North) into 180° (South)  
default: 0°
- Measurement rate: Update interval, adjustable in 250ms, 1 ... 10 s  
default: 10s

### 12.2.8 Pressure Parameters

- Pressure offset: Absolute offset (for on-site adjustment) on the measured value

## Counts of measurements:

Number of measured values used for determining the statistical values of average, minimum value and maximum value  
default: 10

## Relative Humidity

Assumed average value of relative humidity, used for the calculation of air density

## 12.2.9 Analog outputs

Analog Output Parameters	
1 enable	current
1 Channel number	400
1 Min. current [mA]	4
1 Max. current [mA]	20
1 Min. value	0
1 Max. value	90
1 Error current [mA]	2
2 enable	current
2 Channel number	500
2 Min. current [mA]	4
2 Max. current [mA]	20
2 Min. value	0
2 Max. value	359.9
2 Error current [mA]	2
1 Voltage (if used as frequency output)	5

Figure 15: Analog Outputs



**Note:** The analog outputs can only be used if the RS485 interface is operated in half duplex mode and the UMB binary protocol is used

For both analogue outputs the following parameters are available:

Enable:

off: the output is not used  
current: the output is used as a current output  
voltage: the output is used as a voltage output  
frequency: the output is used as a frequency output (only output 1)  
default: off

Channel number:

Number of the measurement channel whose values shall appear  
default: 400 (output 1), 500 (output 2)

Min. and max. current / voltage / frequency:

analogue limitations of the analogue output  
default: 4 – 20 mA

Min. and max. value:

digital limitations of the analogue output  
default: 0 – 90 m/s

Error current:

Current that is delivered in case of an error  
default: 2mA

Voltage (if used as frequency output):

Voltage that represents the high states of the frequency  
default: 5V

**Example:**

The wind speed of 0 – 90 m/s is generated as 4 – 20 mA.

A speed of 20 m/s is therefore generated as

$(20\text{mA}-4\text{mA}) / (90\text{m/s}-0\text{m/s}) * 20\text{m/s} + 4\text{mA} = 7,56\text{mA}$

### 12.3 Value retrieval

- Update the channel list of your *Ventus* then select the channels which you want to query by clicking on them with the mouse, see Figure 16
- Save your settings then change into the data logging menu
- Start the data query, see Figure 17



**Note:** The UMB-ConfigTool.Net is only designed to server for test and configuration purposes. It is not suitable for constantly retrieving data. We recommend the use of a dedicated software for this purpose e.g. SmartView3.

HELP - □ ×
ConfigTool .NET

## Device Details

Name

Device Address

Channels

Number	Name	Type	DataType	Min	Max	
<input checked="" type="checkbox"/>	100	virtual temperature	Cur [°C]	Float32	-50	70
<input type="checkbox"/>	120	virtual temperature	Min [°C]	Float32	-50	70
<input type="checkbox"/>	140	virtual temperature	Max [°C]	Float32	-50	70
<input checked="" type="checkbox"/>	160	virtual temperature	Avg [°C]	Float32	-50	70
<input type="checkbox"/>	105	virtual temperature	Cur [°F]	Float32	-58	158
<input type="checkbox"/>	125	virtual temperature	Min [°F]	Float32	-58	158
<input type="checkbox"/>	145	virtual temperature	Max [°F]	Float32	-58	158
<input type="checkbox"/>	165	virtual temperature	Avg [°F]	Float32	-58	158
<input type="checkbox"/>	112	heater temp. top	Cur [°C]	Float32	-50	150
<input type="checkbox"/>	113	heater temp. bottom	Cur [°C]	Float32	-50	150
<input type="checkbox"/>	117	heater temp. top	Cur [°F]	Float32	-58	302
<input type="checkbox"/>	118	heater temp. bottom	Cur [°F]	Float32	-58	302
<input type="checkbox"/>	300	abs. air pressure	Cur [hPa]	Float32	300	1200
<input type="checkbox"/>	320	abs. air pressure	Min [hPa]	Float32	300	1200
<input type="checkbox"/>	340	abs. air pressure	Max [hPa]	Float32	300	1200
<input type="checkbox"/>	360	abs. air pressure	Avg [hPa]	Float32	300	1200
<input type="checkbox"/>	305	rel. air pressure	Cur [hPa]	Float32	300	1200
<input type="checkbox"/>	325	rel. air pressure	Min [hPa]	Float32	300	1200
<input type="checkbox"/>	345	rel. air pressure	Max [hPa]	Float32	300	1200
<input type="checkbox"/>	365	rel. air pressure	Avg [hPa]	Float32	300	1200
<input checked="" type="checkbox"/>	400	wind speed	Cur [m/s]	Float32	0	90
<input type="checkbox"/>	401	wind speed	Cur [m/s]	Float32	0	90
<input checked="" type="checkbox"/>	420	wind speed	Min [m/s]	Float32	0	90
<input checked="" type="checkbox"/>	440	wind speed	Max [m/s]	Float32	0	90
<input checked="" type="checkbox"/>	460	wind speed	Avg [m/s]	Float32	0	90
<input checked="" type="checkbox"/>	480	wind speed	Vct [m/s]	Float32	0	90
<input type="checkbox"/>	405	wind speed	Cur [km/h]	Float32	0	324
<input type="checkbox"/>	406	wind speed	Cur [km/h]	Float32	0	324
<input type="checkbox"/>	425	wind speed	Min [km/h]	Float32	0	324
<input type="checkbox"/>	445	wind speed	Max [km/h]	Float32	0	324
<input type="checkbox"/>	465	wind speed	Avg [km/h]	Float32	0	324
<input type="checkbox"/>	485	wind speed	Vct [km/h]	Float32	0	324
<input type="checkbox"/>	410	wind speed	Cur [mph]	Float32	0	201
<input type="checkbox"/>	411	wind speed	Cur [mph]	Float32	0	201
<input type="checkbox"/>	430	wind speed	Min [mph]	Float32	0	201
<input type="checkbox"/>	450	wind speed	Max [mph]	Float32	0	201
<input type="checkbox"/>	470	wind speed	Avg [mph]	Float32	0	201
<input type="checkbox"/>	490	wind speed	Vct [mph]	Float32	0	201
<input type="checkbox"/>	415	wind speed	Cur [kts]	Float32	0	175
<input type="checkbox"/>	416	wind speed	Cur [kts]	Float32	0	175
<input type="checkbox"/>	435	wind speed	Min [kts]	Float32	0	175
<input type="checkbox"/>	455	wind speed	Max [kts]	Float32	0	175
<input type="checkbox"/>	475	wind speed	Avg [kts]	Float32	0	175
<input type="checkbox"/>	495	wind speed	Vct [kts]	Float32	0	175
<input checked="" type="checkbox"/>	500	wind direction	Cur [°]	Float32	0	360
<input type="checkbox"/>	501	wind direction	Cur [°]	Float32	0	360
<input type="checkbox"/>	520	wind direction	Min [°]	Float32	0	360
<input type="checkbox"/>	540	wind direction	Max [°]	Float32	0	360
<input type="checkbox"/>	580	wind direction	Vct [°]	Float32	0	360
<input checked="" type="checkbox"/>	805	wind value quality	Cur [%]	Float32	0	100
<input type="checkbox"/>	1048	virtual temperature	Cur [TLS F...]	Sint16	-300	600
<input type="checkbox"/>	1056	wind direction	Vct [TLS F...]	UInt16	0	359
<input type="checkbox"/>	1057	wind speed	Vct [TLS F...]	UInt16	0	600
<input type="checkbox"/>	1064	wind speed	Max [TLS...]	UInt16	0	600
<input type="checkbox"/>	1054	rel. air pressure	Cur [TLS F...]	UInt16	800	1200
<input type="checkbox"/>	4006	supply over voltage	Cur [logic]	UInt8	0	1
<input type="checkbox"/>	4007	supply under voltage	Cur [logic]	UInt8	0	1

Dec
COM4

Figure 16: Channel list

ConfigTool .NET

M16

CAPTURE GRAPH MONITOR

RUN 1s

Ventus 0x8001

Timestamp	virtual temperature 100 [°C] Cur	virtual temperature 160 [°C] Avg	wind speed 400 [m/s] Cur	wind speed 420 [m/s] Min	wind speed 440 [m/s] Max	wind speed 460 [m/s] Avg	wind speed 480 [m/s] Vct	wind direction 500 [°] Cur	wind value quality 805 [%] Cur
12:22:17	16.529	16.615	0.290	0.107	2.733	0.177	0.168	332.074	100.000
12:22:18	16.529	16.615	0.290	0.107	2.733	0.177	0.168	332.074	100.000
12:22:19	16.529	16.615	0.290	0.107	2.733	0.177	0.168	332.074	100.000
12:22:20	16.529	16.615	0.290	0.107	2.733	0.177	0.168	332.074	100.000
12:22:21	16.529	16.615	0.399	0.000	2.733	0.181	0.160	337.649	100.000
12:22:22	16.529	16.615	0.399	0.000	2.733	0.181	0.160	337.649	100.000
12:22:23	16.529	16.615	0.399	0.000	2.733	0.181	0.160	337.649	100.000
12:22:24	16.529	16.615	0.399	0.000	2.733	0.181	0.160	337.649	100.000
12:22:25	16.529	16.615	0.399	0.000	2.733	0.181	0.160	337.649	100.000
12:22:26	16.473	16.612	0.399	0.000	2.733	0.181	0.160	337.649	100.000
12:22:27	16.473	16.612	0.399	0.000	2.733	0.181	0.160	337.649	100.000
12:22:28	16.473	16.612	0.399	0.000	2.733	0.181	0.160	337.649	100.000
12:22:29	16.473	16.612	0.399	0.000	2.733	0.181	0.160	337.649	100.000
12:22:30	16.473	16.612	0.399	0.000	2.733	0.181	0.160	337.649	100.000
12:22:31	16.473	16.612	0.614	0.000	3.321	0.189	0.150	333.401	100.000
12:22:32	16.473	16.612	0.614	0.000	3.321	0.189	0.150	333.401	100.000
12:22:33	16.473	16.612	0.614	0.000	3.321	0.189	0.150	333.401	100.000
12:22:34	16.473	16.612	0.614	0.000	3.321	0.189	0.150	333.401	100.000

Dec COM4

Figure 17: Data query

## 13 Firmware Update

In order to keep the sensor up to date a firmware update can be done on site. Updates can be carried out with company Lufft's configuration software UMB-ConfigTool.Net.

You will find the PC version on the Lufft homepage: <https://www.lufft.com/resources/>

Download the software UMB-ConfigTool.Net and install it on your computer. Use the online help of the software in order to get familiar with the program in general and especially with how to carry out a firmware update on a Lufft sensor.

On the same internet site you will find the current firmware versions of all Lufft products.

For the *Ventus*, download the firmware „Firmware - Lufft - Ventus-UMB“ then load it onto the *Ventus* as described in the online help of the UMB-ConfigTool.Net.

**A firmware update can only be carried out in half duplex operation mode!**



## 14 Maintenance

In principle the equipment is maintenance-free.

However, it is recommended to carry out a functional test on an annual basis. When doing so, pay attention to the following points:

- Visual inspection of the equipment for soiling
- Check the sensors by carrying out a measurement request

## 15 Technical Data

Power supply:	24 VDC $\pm$ 10%
	18 – 26.4 VDC if <b>no</b> heating is used
Current consumption and power input – sensor without heater ( <b>Ventus &amp; V200A</b> ):	ca. 77mA / 1.2VA at 24 VDC
Current consumption and power input with heating ( <b>Ventus</b> ):	max. 10A / 230 VA at 24 VDC
Current consumption and power input with heating ( <b>Ventus-X</b> ):	max. 10A / 240VA at 24 VDC
Current consumption and power input with heating ( <b>V200A</b> ):	max. 1000mA / 21.6 VA at 24 VDC

Dimensions including mounting bracket:

Ø 150mm, height 170mm

Weight including mounting bracket, excluding connection cable:

ca. 1.62 kg (metal)

ca. 0,80 kg (plastics)

Fastening: Pole with Ø 50mm

Housing:	Seawater-resistant aluminum AlMg3Si
Protection class:	III (SELV)
Protection type:	IP68 (metal)
	IP66 (plastics)

Storage conditions

Permissible storage temperature: -55°C ... +80°C

Permissible relative humidity: 0 ... 95% RH

Non-condensing

Operating conditions

Permissible operating temperature: -40°C ... +60°C (with heating)

Permissible operating temperature: -20°C ... +60°C (without heating)

Permissible relative humidity: 0 ... 100% RH

Permissible altitude above sea level: N/A

RS485 interface, 2<sup>1</sup> or 4 wire, half<sup>1</sup> or full duplex

Data bits: 8 (SDI-12 mode: 7)

Stop bit: 1

Parity: No (SDI-12 mode: even)

Tri-state: 2 bits after stop bit edge

Adjustable baud rates: 1200, 2400, 4800, 9600, 14400, 19200<sup>1</sup>, 28800, 57600

(when entering SDI-12 mode the circuit is switched to conform to the standard's requirements)

Analog interface circuits: A: 0 or 4 - 20mA / 0 or 2 – 10V / 2 – 2000Hz

B: 0 or 4 - 20mA / 0 or 2 – 10V

Maximum load: 300  $\Omega$  (in current mode)

Resolution: 16 bits

Channels: Adjustable

Update rate: 250ms; 1-10 seconds

<sup>1</sup> Factory setting and baud rate for firmware update



**15.1 Measuring Range / Accuracy****15.1.1 Wind Speed**

Measurement process:	Ultrasound
Measuring range:	0 – 90m/s
Resolution:	0.1 m/s
Accuracy:	±0,2 m/s or ±2% (0 ... 65m/s) RMS (metal) (the higher value) ±5% (> 65m/s) RMS (metal)
	±0,3 m/s oder ±3% (0 ... 35m/s) RMS (plastics) (the higher value) ±5% (> 35m/s) RMS (plastics)
Response threshold (adjustable):	0.1 m/s (metal) 0.3 m/s (plastics)
Sampling rate:	250ms; 1-10 seconds
Units:	m/s; km/h; mph; kts

**15.1.2 Wind Direction**

Measurement process:	Ultrasound
Measuring range:	0 – 359.9°
Resolution:	0.1°
Accuracy:	<2° (> 1m/s) RMSE (metal) < 3° (> 1m/s) RMSE (plastics)
Response threshold (adjustable):	0.1 m/s (metal) 0.3 m/s (plastics)
Sampling rate:	250ms; 1-10 seconds

**15.1.3 Virtual Temperature**

Measurement process:	Ultrasound
Measuring range:	-50°C ... +70°C
Resolution:	0.1°C
Sensor accuracy:	+/- 2.0 K (unheated and without solar irradiation or wind speed above 4 m/s)
Sampling rate:	1-10 seconds
Units:	°C; °F

**15.1.4 Air Pressure**

Measurement process:	MEMS sensor - capacitive
Measuring range:	300 ... 1200hPa
Resolution:	0.1hPa
Accuracy:	+/- 1.5hPa
Sampling rate:	10sec
Unit:	hPa

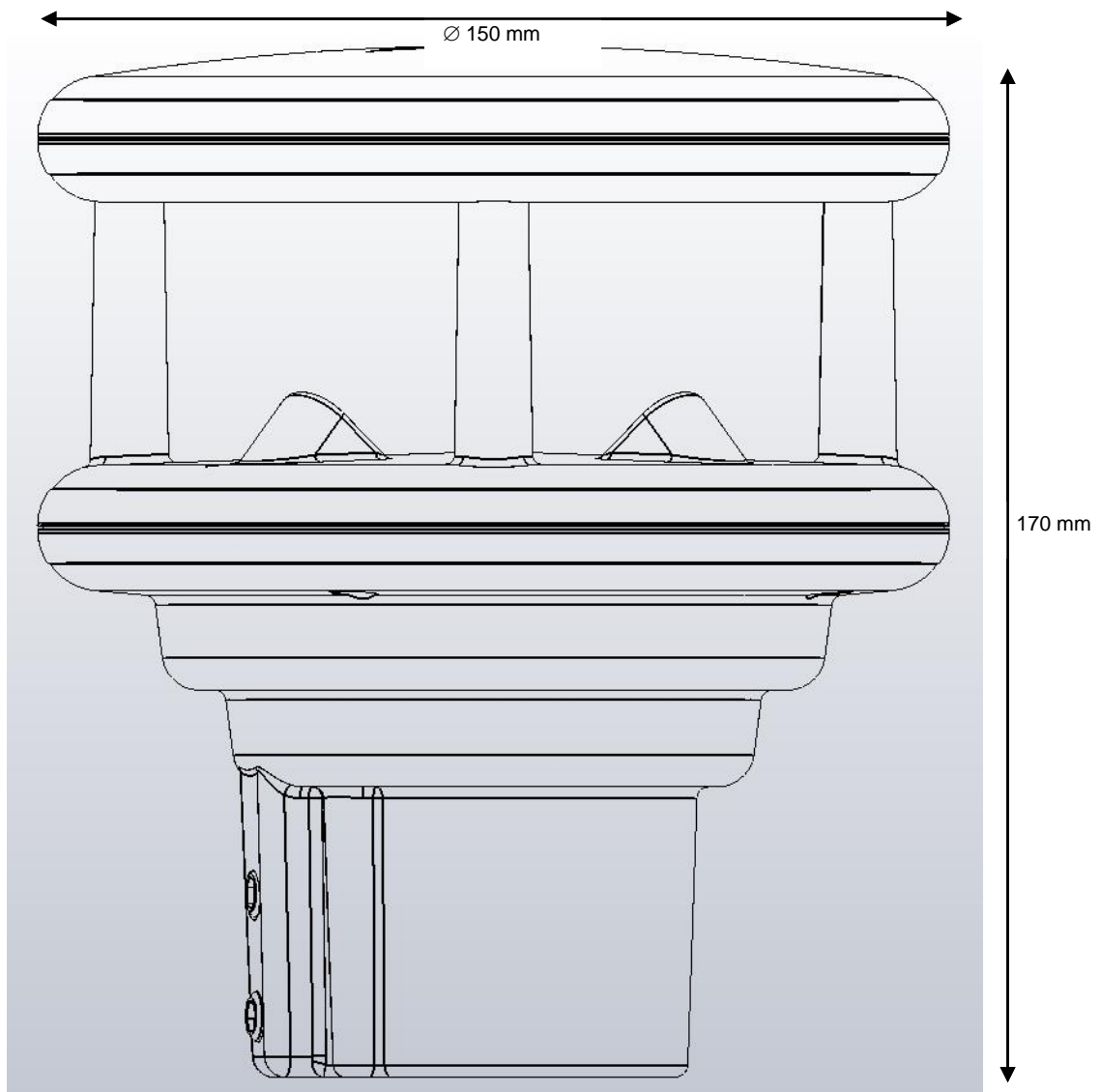
**15.2 Drawing**Figure 18: Drawing **Ventus**

## **16 EC Declaration of Conformity**

**Product:** Wind Meter  
**Type:** Ventus (Bestell-Nr.: 8371.UMT)  
VentusX (Bestell-Nr.: 8371.UMTX)  
V200A (Bestell-Nr.: 8371.UA01)

We hereby confirm that the above mentioned instruments on the basis of their conception and construction comply with EUR directive according to

EU-Directive 2014/30/EU: elektromagnetic compatibility

EU-Directive 2011/65/EU: RoHS-Directive

The complete declaration can be downloaded from our homepage [www.lufft.com](http://www.lufft.com)

**17 Fault Description**

<b>Fault Description</b>	<b>Cause - Remedy</b>
The device does not allow polling or does not respond	<ul style="list-style-type: none"> <li>- Check supply voltage</li> <li>- Check interface connection</li> <li>- False device ID → check ID; devices are delivered with ID 1.</li> </ul>
Wind direction transmits incorrect values	Device not correctly aligned → check alignment of device to North.
Device transmits error value 28h (40d)	Device is in initialization phase after start-up → device delivers measurement values after ca. 10 seconds
Device transmits error value 50h (80d)	Device is being operated above the specified measuring range
Device transmits error value 51h (81d)	Device is being operated below the specified measuring range
Device transmits error value 55h (85d) for wind measurement	<p>Device unable to carry out valid measurement due to ambient conditions.</p> <p>There may be several causes for this:</p> <ul style="list-style-type: none"> <li>- Device is being operated above the specified measuring range</li> <li>- Very strong horizontal rain or snowfall</li> <li>- <b>Ventus</b> sensors are heavily soiled → clean sensor</li> <li>- <b>Ventus</b> sensors are iced up → check heating mode in configuration and verify function / connection of heating</li> <li>- There are foreign bodies in the <b>Ventus</b> measuring section</li> <li>- One of the <b>Ventus</b> sensors is faulty → return device to manufacturer for repair</li> </ul>
The quality of the wind measurement is not always 100%	<p>The device should always transmit 90 – 100% in normal operation. Values of up to 50% do not represent a general problem.</p> <p>When error value 55h (85d) is transmitted, this value is 0%.</p> <p>The device may be faulty if it permanently transmits values below 50%.</p>
Device transmits an error value not listed here	There may be several reasons for this behavior → contact the manufacturer's technical support service.
Minimum value of wind direction is greater than maximum value	In the case of wind direction, the minimum / maximum value indicates the direction at which the minimum / maximum wind speed was measured.

## 18 Disposal

### 18.1 Within the EC

The device must be disposed of in accordance with European Directives 2002/96/EC and 2003/108/EC (waste electrical and electronic equipment).

### 18.2 Outside the EC

Please comply with the applicable regulations for the proper disposal of waste electrical and electronic equipment in your respective country.

## 19 Repair / Corrective Maintenance

Please arrange for any faulty equipment to be checked and, if necessary, repaired by the manufacturer exclusively. Do not open the equipment and do not under any circumstances attempt to carry out your own repairs.

In matters of warranty or repair please contact:

### **G. Lufft Mess- und Regeltechnik GmbH**

Gutenbergstraße 20  
70736 Fellbach

P.O. Box 4252  
70719 Fellbach

Germany

Tel: +49 711 51822-0

Hotline: +49 711 51822-52

Fax: +49 711 51822-41

E-Mail: [info@lufft.com](mailto:info@lufft.com)

or your local distributor.

### 19.1 Technical Support

Our Hotline is available for technical questions via the following e-mail address:

[hotline@lufft.de](mailto:hotline@lufft.de)

You can also consult frequently asked questions at <http://www.lufft.com/> (menu header: FAQs).

## 20 Appendix

### 20.1 Channel List Summary

The channel assignment described here applies to online data requests in binary and ASCII protocol.

UMB Channel					special	Measurement Variable (float)	Measuring Range		
act	min	max	avg	min			max	unit	
<b>Temperature</b>									
100	120	140	160			virtual temperature	-50.0	70.0	°C
105	125	145	165			virtual temperature	-58.0	158.0	°F
112						Heating temperature top	-50.0	150.0	°C
113						Heating temperature bottom	-50.0	150.0	°C
117						Heating temperature top	-58.0	302.0	°F
118						Heating temperature bottom	-58.0	302.0	°F
<b>Air Pressure</b>									
300	320	340	360			Absolute air pressure	300.0	1200.0	hPa
305	325	345	365			Relative air pressure	300.0	1200.0	hPa
310						Air density	0.0	3.0	kg/m <sup>3</sup>
<b>Wind</b>									
				<b>vect. avg</b>					
400	420	440	460	480		wind speed	0	90.0	m/s
405	425	445	465	485		wind speed	0	324.0	km/h
410	430	450	470	490		wind speed	0	201.3	mph
415	435	455	475	495		wind speed	0	174.8	kts
443						wind gust speed	0	90.0	m/s
448						wind gust speed	0	324.0	km/h
453						wind gust speed	0	201.3	mph
458						wind gust speed	0	174.8	kts
500	520	540		580		wind direction	0	359.9	°
543						wind gust direction	0	359.9	°
805						wind value quality	0	100,0	%
<b>Status Information</b>									
4006						Status supply voltage, upper threshold (~ 28V)	0 : Voltage <= 28V 1: Voltage > 28V		
4007						Status supply voltage, lower threshold (~ 20V)	0 : Voltage >= 20V 1: Voltage < 20V		
4997						Status lower heating	0: Heating off 1: Heating on		
4998						Status upper heating	0: Heating off 1: Heating on		

## 20.2 Channel List Summary per TLS2002 FG3

The following channels are available specifically for data requests for further processing in TLS format. These channels are available in binary protocol only.

DE Type	UMB Channel	Meaning	Format	Range	Resolution	Coding
48	1048	Result message Air Temperature AT	16 bit	-30 ... +60°C	0.1°C	60.0 = 600d = 0258h 0.0 = 0d = 0000h -0.1 = -1d = FFFFh -30.0 = -300d = FED4h
54	1054	Result Message Air Pressure LD	16 bit	800 ... 1200 hPa	1 hPa	800 = 800d = 0320h 1200 = 1200d = 04B0h
56	1056	Result message Wind Direction WD	16 bit	0 ... 359°	1°	0° (N) = 0d = 0000h 90° (O) = 90d = 005Ah 180° (S) = 180d = 00B4h 270° (W) = 270d = 010Eh FFFFh = not definable
57	1057	Result message Wind Speed. (average) WSA	16 bit	0.0 ... 90.0 m/s	0.1 m/s	0.0 = 0d = 0000h 90.0 = 900d = 0384h
64	1064	Result message Wind Speed (peak) WSP	16 bit	0.0 ... 90.0 m/s	0.1 m/s	0.0 = 0d = 0000h 90.0 = 900d = 0384h

### 20.3 Communication in Binary Protocol

Only one example of an online data request is described in this operating manual. Please refer to the current version of the UMB Protocol for all commands and the exact mode of operation of the protocol (available for download at [www.lufft.com](http://www.lufft.com)).

**Note:** Communication with the sensor takes place in accordance with the master-slave principle, i.e. there may only be ONE requesting unit on a network.

#### 20.3.1 Framing

The data frame is constructed as follows:

1	2	3 - 4	5 - 6	7	8	9	10	11 ... (8 + len) optional	9 + len	10 + len 11 + len	12 + len
SOH	<ver>	<to>	<from>	<len>	STX	<cmd>	<verc>	<payload>	ETX	<cs>	EOT

SOH	Control character for the start of a frame (01h); 1 byte
<ver>	Header version number, e.g.: V 1.0 → <ver> = 10h = 16d; 1 byte
<to>	Receiver address; 2 bytes
<from>	Sender address; 2 bytes
<len>	Number of data bytes between STX and ETX; 1 byte
STX	Control character for the start of payload transmission (02h); 1 byte
<cmd>	Command; 1 byte
<verc>	Version number of the command; 1 byte
<payload>	Data bytes; 0 – 210 bytes
ETX	Control character for the end of payload transmission (03h); 1 byte
<cs>	Check sum, 16 bit CRC; 2 bytes
EOT	Control character for the end of the frame (04h); 1 byte

Control characters: SOH (01h), STX (02h), ETX (03h), EOT (04h).

#### 20.3.2 Addressing with Class and Device ID

Addressing takes place by way of a 16 bit address. This breaks down into a Class ID and a Device ID.

Address (2 bytes = 16 bit)			
Bits 15 – 12 (upper 4 bits)		Bits 11 – 8 (middle 4 bits)	Bits 7 – 0 (lower 8 bits)
Class ID (0 to 15)		Reserve	Device ID (0 – 255)
0	Broadcast		0 Broadcast
8	<b>Ventus</b>		1 - 255 Available
15	Master or control devices		

ID = 0 is provided as broadcast for classes and devices. Thus it is possible to transmit a broadcast on a specific class. However this only makes sense if there is only one device of this class on the bus; or in the case of a command, e.g. reset.

#### 20.3.3 Examples for Creating Addresses

If, for example, you want to address **Ventus** with the device ID 001, this takes place as follows:

The class ID for the **Ventus** is 8d = 8h;

the device ID is e.g. 001d = 01h

Putting the class and device IDs together gives the address 8001h (32769d).

#### 20.3.4 Example of a Binary Protocol Request

If, for example, a **Ventus** with the device ID 001 is to be polled from a PC for the current temperature, this takes place as follows:



**Sensor:**

The class ID for the *Ventus* is 8 = 8h;

the device ID is 001 = 01h

Putting the class and device IDs together gives a target address of 8001h.

**PC:**

The class ID for the PC (master unit) is 15 = Fh;

the PC ID is e.g. 001d = 01h

Putting the class and device IDs together gives a sender address of F001h.

The length <len> for the online data request command is 4d = 04h;

the command for the online data request is 23h;

the version number of the command is 1.0 = 10h.

The channel number is in <payload>; as can be seen from the channel list (page 38), the current temperature in °C in the channel is 100d = 0064h.

The calculated CRC is 540Bh.

**The request to the device:**

SOH	<ver>	<to>		<from>		<len>	STX	<cmd>	<verc>	<channel>		ETX	<cs>		EOT
1	2	3	4	5	6	7	8	9	10	11	12	13	14	15	16
01h	10h	01h	80h	01h	F0h	04h	02h	23h	10h	64h	00h	03h	0Bh	54h	04h

**The response from the device:**

SOH	<ver>	<to>		<from>		<len>	STX	<cmd>	<verc>	<status>	<channel>		<typ>
1	2	3	4	5	6	7	8	9	10	11	12	13	14
01h	10h	01h	F0h	01h	80h	0Ah	02h	23h	10h	00h	64h	00h	16h

<value>				ETX	<cs>		EOT
15	16	17	18	19	20	21	22
00h	00h	B4h	41h	03h	1Fh	94h	04h

**Interpretation of the response:**

<status> = 00h device o.k. (≠ 00h signifies error code; see page 42)

<typ> = Data type of the following value; 16h = float (4 bytes, IEEE format)

<value> = 41B40000h corresponds to a float value of 22.5

The temperature is therefore 22.5°C.

The correct data transmission can be checked with the aid of the check sum (941Fh).

**Note:** Little Endian (Intel, low byte first) applies when transmitting word and float variables of addresses or the CRC, for example. This means first the low byte and then the high byte.



**20.3.5 Status and Error Codes in Binary Protocol**

If a measurement request delivers the <status> 00h, the sensor is working correctly. You can find a complete list of additional codes in the description of the UMB protocol.

Extract from list:

<status>	Description
00h (0d)	Command successful; no error; all o.k.
10h (16d)	Unknown command; not supported by this device
11h (17d)	Invalid parameter
24h (36d)	Invalid channel
28h (40d)	Device not ready; e.g. initialization / calibration running
50h (80d)	Measurement variable (+offset) is outside the set display range
51h (81d)	
52h (82d)	Measurement value (physical) is outside the measuring range (e.g. ADC over range)
53h (83d)	
54h (84d)	Error in measurement data or no valid data available
55h (85d)	Device /sensor unable to carry out valid measurements due to ambient conditions

**20.3.6 CRC Calculation**

CRC is calculated according to the following rules:

Norm: CRC-CCITT

Polynomial:  $1021h = x^{16} + x^{12} + x^5 + 1$  (LSB first mode)

Start value: FFFFh

You can find further information in the description of a CRC calculation in UMB Protocol.

## 20.4 Communication in ASCII Protocol

**Note:** UMB-ASCII protocol is not recommended for new projects. New features will not be implemented for this protocol for devices newer than device version 36.

Text-based communication with devices is possible using ASCII protocol.

To do this, in the device configuration, interface settings, the protocol mode must be set to ASCII (see page 25).

ASCII protocol is network-compatible and serves exclusively for online data requests. The device will not respond to incomprehensible ASCII commands.

**Note:** The use of binary protocol is recommended for lengthy transmission routes (e.g. network, GPRS/UMTS), as ASCII protocol is unable to detect transmission errors (not CRC-secured).

**Note:** TLS channels are not available in ASCII protocol.

### 20.4.1 Structure

An ASCII command is introduced by the '&' character and completed by the CR (0Dh) sign. There is a space character (20h) between the individual blocks in each case; this is represented by an underscore character '\_'. Characters that represent an ASCII value are in ordinary inverted commas.

### 20.4.2 Summary of ASCII Commands

Command	Function	BC	AZ
M	Online data request		l
X	Switches to binary protocol		k
R	Triggers software reset	•	k
D	Software reset with delay	•	k
I	Device information		k

These operating instructions describe the online data request only. You can find the description of the other commands in the UMB protocol.

### 20.4.3 Online Data Request (M)

**Description:** By way of this command, a measurement value is requested from a specific channel.

**Request:** '&'\_<ID><sup>5</sup>'M'\_<channel><sup>5</sup> CR

**Response:** '\$'\_<ID><sup>5</sup>'M'\_<channel><sup>5</sup><value><sup>5</sup> CR

<ID><sup>5</sup> Device address (5 decimal places with leading zeros)

<channel><sup>5</sup> Indicates the channel number (5 decimal places with leading zeros)

<value><sup>5</sup> Measurement value (5 decimal places with leading zeros); a measurement value standardized to 0 – 65520d. Various error codes are defined from 65521d – 65535d.

**Example:**

Request: &\_32769\_M\_00100

By way of this request, channel 100 of the device with address 32769 (*Ventus* with device ID 001).

Response: \$\_32769\_M\_00100\_34785

This channel outputs a temperature from –40 to +60°C; this results in the following calculation:

0d corresponds to -50°C

65520d corresponds to +70°C

36789d corresponds to  $[+70^{\circ}\text{C} - (-50^{\circ}\text{C})] / 65520 * 34785 + (-50^{\circ}\text{C}) = 13,7^{\circ}\text{C}$

**Note:** TLS channels are not available in ASCII protocol.

**20.4.4 Standardization of Measurement Values in ASCII Protocol**

The standardization of measurement values from 0d – 65520d corresponds to the measuring range of the respective measurement variable.

Measurement Variable	Measuring Range		
	min	max	unit
<b>Temperature</b>			
Temperature	-50.0	70.0	°C
	-58.0	158.0	°F
<b>Air Pressure</b>			
Relative air pressure Absolute air pressure	300,0	1200,0	hPa
<b>Wind</b>			
Wind speed	0.0	90.0	m/s
	0.0	324.0	km/h
	0.0	201.3	mph
	0.0	174.8	kts
Wind direction	0.0	359.9	°
Quality of wind measurement	0.0	100.0	%

**20.4.5 Status and Error Codes in ASCII Protocol**

Various error codes are defined from 65521d – 65535d in addition to the standardization of measurement values.

**Codes:**

<code>	Description
65521d	Invalid channel
65523d	Measurement value outside measuring range (too high)
65524d	Measurement value outside measuring range (too low)
65525d	Measurement data error or no valid data available
65526d	Device / sensor unable to execute valid measurement due to ambient conditions
65534d	Invalid calibration
65535d	Unknown error

## 20.5 Communication in NMEA Protocol

Wind direction and wind speed in accordance with NMEA protocol can be requested via the NMEA protocol.

To do this, in the device configuration, interface settings, the protocol mode must be set to NMEA (see page 25).

NMEA protocol is network-compatible and serves exclusively for online data requests. The device will not respond to incomprehensible NMEA commands.

**Note:** The use of binary protocol is recommended for lengthy transmission routes (e.g. network, GPRS/UMTS), as NMEA protocol is unable to detect transmission errors (not CRC-secured).

**Note:** In the NMEA protocol, data output is available by means of NMEA telegram only.

In the NMEA protocol, it is possible to control the telegram output by means of the control line when using full duplex operation (see page 20).

### 20.5.1 Structure

An NMEA command is initiated by the ID and concluded with the CR sign (0Dh). Characters that represent an ASCII value are in ordinary inverted commas.

### 20.5.2 ID

The NMEA-ID is derived from the UMB-ID, by deducting 1.

Example:       UMB-ID:       1  
                  NMEA-ID:     0

### 20.5.3 Summary of NMEA commands

Command	Function
TR	Telegram request NMEA / VDT
TT	Independent telegram transmission NMEA / VDT
KY	Access mode (read only/admin)
DM	Duplex mode
BR	Baudrate
RD	Response delay
HP	Heating duty
HT	Heating mode
ID	Device ID
MD	Measurement interval
OR	Output interval
AV	Averaging interval
OS	Scaling of wind speed
NC	North correction
RS	Triggers software reset
TG	Control line trigger property
XX	Switches to binary protocol

Differentiation is made between 2 authorization levels when sampling:

- Read only and
- Admin

The settings for all parameters can be requested in both modes but can only be changed in "Admin" mode. In "Read only" mode it is only possible to enable/disable automatic telegram transmission and to trigger a software reset.

### 20.5.4 Telegram Request (NMEA)

**Description:** This command requests the NMEA telegram.

**Request:** <ID>'TR4'(CR)

<ID>           Device address (2 decimal places with leading zeros)

**Response:** \$xxMwV,xxx.x,R,xxx.x,M,A\*xx(CR)(LF)  
 \$xxMwV, Message ID, xx is the device type ID, factory default: WI, i.e. message ID \$WIMwV (setting of the device type ID see page 25)  
 xxx.x Wind direction  
 ,R, fix  
 xxx.x Wind speed  
 , fix  
 M Possible values K,N,M,S for km/h, Knots, m/s, mph  
 , fix  
 A A=valid value, V= invalid value  
 \* Check sum identifier  
 xx Check sum as hex value  
 CR Carriage Return  
 LF Line Feed

**Response in case of error**

**Request:** <ID>'TR4'(CR)  
 <ID> Device address (2 decimal places with leading zeros)  
**Response:** \$xxMwV,,R,,M,V\*xx(CR)(LF)  
 \$xxMwV, Message ID, see above  
 ,R, fix  
 , fix  
 M Possible values K,N,M,S for km/h, Knots, m/s, mph  
 , fix  
 V V= invalid value  
 \* Check sum identifier  
 xx Check sum as hex value  
 CR Carriage Return  
 LF Line Feed

**Example:**

Request: 01TR4

Response: \$WIMwV,230.6,R,003.4,N,A\*23

This means that the wind is coming at a speed of 3.4 knots from 230.6°

### 20.5.5 Telegram Request (VDT)

**Description:** This command requests the VDT telegram.

**Request:** <ID>'TR2'(CR)  
 <ID> Device address (2 decimal places with leading zeros)  
**Response:** <STX>xx.x xxx xxx.x xx\*xx <CR><ETX>  
 <STX> Start of Text (0x02)  
 xx.x Wind speed in m/s  
 xxx Wind direction °  
 xxx.x Air temperature (virt.) in °C signed +/-  
 xx Status as hex value (s. below)  
 \* Check sum identifier  
 xx Check sum as hex value  
 <CR> Carriage Return (0x0D)  
 <ETX> End of Text (0x03)

#### Response in case of error

**Request:** <ID>,TR2'(CR)  
 <ID> Geräteadresse (2-stellig dezimal mit führenden Nullen)  
**Response:** <STX>FF.F FFF FFF.F xx\*xx <CR><ETX>  
 <STX> Start of Text (0x02)  
 FF.F Wind speed not OK  
 FFF Wind direction not OK  
 FFF.F Air temperature (virt.) not OK  
 xx Status as hex value (s. below)  
 \* Check sum identifier  
 xx Check sum as hex value  
 <CR> Carriage Return (0x0D)  
 <ETX> End of Text (0x03)

#### Example:

Request: 01TR2

Response: <ETX>00.2 163 +24.2 00\*39

This means wind with 0,2 m/s from 163°, the air temperature is 24.2°C

#### Status:

Bit 0:	Status wind measurement	0 = OK	1 = not OK
Bit 1:	Status temperature measurement	0 = OK	1 = not OK
Bit 2	reserved	0	
Bit 3	Heating	0 = off	1 = on
Bit 4 – 7	reserved	0	

### 20.5.6 Independent Telegram Transmission (NMEA)

**Description:** This command is used to disable/enable independent transmission of the NMEA telegram. Independent transmission can be enabled in full duplex mode only.

**Response:** <ID>'TT'<value>(CR)

<ID> Device address (2 decimal places with leading zeros)

<value> 0...disabled

4...enabled

The current setting is delivered as the response if no entry is made for <value>.

**Response:** \$xxMWW,xxx.x,R,xxx.x,M,A\*xx(CR)(LF) every 1-10 seconds (depending on MD)

\$xxMWW, Message ID, xx is the device type ID, factory default: WI, i.e. message ID \$WIMWW (setting of the device type ID see page 25)

xxx.x Wind direction

,R, fix

xxx.x Wind speed

, fix

M Possible values K,N,M,S for km/h, Knots, m/s, mph

, fix

A A=valid value, V= invalid value

\* Check sum identifier

xx Check sum (high byte first)

CR Carriage Return

LF Line Feed

#### Response in case of error

**Request:** <ID>'TT'<value>(CR)

<ID> Device address (2 decimal places with leading zeros)

<value> 0...disabled

4...enabled

**Response:** \$WIMWW,,R,,M,V\*xx(CR)(LF)

\$WIMWW, fix

,R, fix

, fix

M Possible values K,N,M,S for km/h, Knots, m/s, mph

, fix

V V= invalid value

\* Check sum identifier

xx Check sum (high byte first)

CR Carriage Return

LF Line Feed



### 20.5.7 Independent Telegram Transmission (VDT)

**Description:** This command is used to disable/enable independent transmission of the VDT telegram. Independent transmission can be enabled in full duplex mode only.

**Response:** <ID>'TT'<value>(CR)

<ID> Device address (2 decimal places with leading zeros)

<value> 0...disabled

2...enabled

The current setting is delivered as the response if no entry is made for <value>.

**Response:** <STX>xx.x xxx xxx.x xx\*xx <CR><ETX>

<STX> Start of Text (0x02)

xx.x Wind speed in m/s

xxx Wind direction °

xxx.x Air temperature (virt.) in °C signed +/-

xx Status as hex value (s. below)

\* Check sum identifier

xx Check sum as hex value

<CR> Carriage Return (0x0D)

<ETX> End of Text (0x03)

#### Response in case of error

**Response:** <STX>FF.F FFF FFF.F xx\*xx <CR><ETX>

<STX> Start of Text (0x02)

FF.F Wind speed not OK

FFF Wind direction not OK

FFF.F Air temperature (virt.) not OK

xx Status as hex value (s. below)

\* Check sum identifier

xx Check sum as hex value

<CR> Carriage Return (0x0D)

<ETX> End of Text (0x03)

#### Status:

Bit 0: Status wind measurement 0 = OK 1 = not OK

Bit 1: Status temperature measurement 0 = OK 1 = not OK

Bit 2 reserved 0

Bit 3 Heating 0 = off 1 = on

Bit 4 – 7 reserved 0

### 20.5.8 Access Mode

**Description:** This command is used to switch between Read only and Admin modes.

**Request:** <ID>'KY'<key>(CR)  
 <ID> Device address (2 decimal places with leading zeros)  
 <key> 0 Read only  
 4711 Admin

It is possible to set all parameters in Admin mode only. The parameters are effective immediately after setting; however they are only stored permanently in the sensor in Read only mode **after** quitting Admin mode. Parameters that were changed in error but not yet saved can be reset by briefly disconnecting the sensor from the power supply.

**Response on change from Read only mode to Admin mode:**

```
!00KY04711
Setting rights -> ADMIN
Save new configuration with 'idKY00'
```

**Response on change from Admin mode to Read only mode:**

```
!00KY00000
Setting rights -> READ ONLY
Configuration saved.
```

### 20.5.9 Duplex Mode

**Description:** This command is used to switch between half and full duplex.



**Note:** Switchover takes place immediately, i.e. a suitable communication module must then be connected to the sensor. If the switchover is made in error, the previous setting can be restored by briefly disconnecting the sensor from the power supply.

**Request:** <ID>,'DM'<value>(CR)  
 <ID> Device address (2 decimal places with leading zeros)  
 <value> 0 ...half duplex  
 1...full duplex

The current setting is delivered as the response if no entry is made for <value>.

**Response:** !<ID>'DM'<value>(CR)

### 20.5.10 Baud Rate

**Description:** This command sets baud rate and parity.

**Note:** The switchover is effective after the next reset. To activate the new settings a reset must be initiated by reset command or by briefly disconnecting the sensor from the power supply.

**Request:** <ID>,'BD'<value>(CR)

<ID> Device address (2 decimal places with leading zeros)

<value> baud rate / parity code (see table below)

The current setting is delivered as the response if no entry is made for <value>.

**Response:** !<ID>'BD'<value>(CR)

#### Table of Baud Rate Codes

Code	Baud Rate	Parity
0	reserved	
1	reserved	
2	1200	8N1
3	2400	8N1
4	4800	8N1
5	9600	8N1
<b>6</b>	<b>19200</b>	<b>8N1</b>
7	38400	8N1
8	57600	8N1
9	reserved	
10	1200	7E1
11	2400	7E1
12	4800	7E1
13	9600	7E1
14	19200	7E1
15	38400	7E1
16	57600	7E1
17	reserved	

### 20.5.11 Response Delay

**Description:** This command sets the response delay after NMEA requests.

**Request:** <ID>,'RD'<value>(CR)

<ID> Device address (2 decimal places with leading zeros)

<value> 0 ... 1000 delay time in msec

The current setting is delivered as the response if no entry is made for <value>.

**Response:** !<ID>'RD'<value>(CR)

### 20.5.12 Heating Duty

**Description:** This command is used to switch between full and half heating duty.

**Request:** <ID>,'HP'<value>(CR)

<ID> Device address (2 decimal places with leading zeros)

<value> 0 ...full heating duty  
1... alternating heating

The current setting is delivered as the response if no entry is made for <value>.

**Response:** !<ID>'HP'<value>(CR)

### 20.5.13 Heating Mode

**Description:** This command is used to switch between 4 heating modes. The trigger property TG is automatically set to 0 (disabled) when the setting values are 3 or 4.

**Request:** <ID>'HT'<value>(CR)

<ID> Device address (2 decimal places with leading zeros)

<value> 0: Heating is always off

1: Heating is automatically controlled<sup>1</sup>

Heating switches on when the housing temperature falls below +2°C (adjustable between 2°C and 10°C) and switches off at a housing temperature of >+7°C (set temperature +5°C)

2: The switch-on temperature is shifted to +40°C; thus the heating switches on at room temperature (for test purposes only)

3: Heating is disabled when the control line is at "high" level, otherwise automatic

4: Heating is disabled when the control line is at "low" level, otherwise automatic

The current setting is delivered as the response if no entry is made for <value>.

**Response:** !<ID>'HT'<value>(CR)

### 20.5.14 Device ID

**Description:** This command is used to set the sensor ID.

**Request:** <ID>'ID'<value>(CR)

<ID> Device address (2 decimal places with leading zeros)

<value> New ID

The current setting is delivered as the response if no entry is made for <value>.

**Response:** !<ID>'ID'<value>(CR)

### 20.5.15 Measurement Interval

**Description:** This command is used to set the measurement interval.

**Request:** <ID>'MD'<value>(CR)

<ID> Device address (2 decimal places with leading zeros)

<value> 0 or 1..10 seconds (0: measurement interval 250msec)

The current setting is delivered as the response if no entry is made for <value>.

**Response:** !<ID>'MD'<value>(CR)



**Note:** A modification of the measurement interval will be effective only after a device restart.

<sup>1</sup> Factory setting

### 20.5.16 Output Interval

**Description:** This command is used to set the time interval for telegram transmission when independent telegram transmission (TT) is enabled.

**Request:** <ID>'OR'<value>(CR)

<ID> Device address (2 decimal places with leading zeros)

<value> 10..10000 milliseconds

The current setting is delivered as the response if no entry is made for <value>.

**Response:** !<ID>'OR'<value>(CR)



**Note:** The minimal output interval depends on the given baudrate:

baudrate [baud]	Minimal output interval [ms]
1200	250
2400	130
4800	70
9600	40
14400	30
19200	20
28800	20
57600	10

### 20.5.17 Averaging Interval

**Description:** This command is used to set the averaging interval of the wind sensor.

**Request:** <ID>'AV'<value>(CR)

<ID> Device address (2 decimal places with leading zeros)

<value> 0 NMEA output commands use instantaneous values

1 ... 1200 Interval in 1/10 seconds (max 120sec)

The current setting is delivered as the response if no entry is made for <value>.

**Response:** !<ID>'AV'<value>(CR)



**Note:** The AV command sets both measurement interval and number of samples used for calculation of average and min/max. Measurement rate is set to the shortest interval permitted with the required averaging interval:

0.1sec to 15sec: measurement interval 250msec

More than 15sec up to 60sec: measurement interval 1sec

More than 60sec up to 120sec: measurement interval 2sec

AV command with parameter 0 does not modify the measurement interval.

A modification of the measurement interval is effective only after a device restart.

### 20.5.18 Scaling the Wind Speed

**Description:** This command is used to set the unit for wind speed.

**Request:** <ID>'OS'<value>(CR)

<ID> Device address (2 decimal places with leading zeros)

<value> 0 ...m/s

1...km/h

2...miles/h

3...knots

The current setting is delivered as the response if no entry is made for <value>.

**Response:** !<ID>'OS'<value>(CR)

### 20.5.19 North Correction of the Wind Direction

**Description:** This command is used to set the north correction of the wind direction. This allows to adjust to sensor installation deviations.

**Request:** <ID>'NC'<value>(CR)

<ID> Device address (2 decimal places with leading zeros)

<value> 0 ... 360 Correction value in °

The current setting is delivered as the response if no entry is made for <value>.

**Response:** !<ID><value>(CR)

### 20.5.20 Control line trigger property

**Description:** This command is used to set the trigger property when independent telegram transmission (TT) is enabled. If when enabling the function the heating control setting is 3 or 4 (control via control line), this (automatically) switches to 1.

**Request:** <ID>'TG'<value>(CR)

<ID> Device address (2 decimal places with leading zeros)

<value> 0: Disabled/heating control

1:Telegram transmission triggered on rising edge of control voltage

2:Telegram transmission triggered on falling edge of control voltage

3:Telegram transmission while control voltage is "high"

4:Telegram transmission while control voltage is "low"

The current setting is delivered as the response if no entry is made for <value>.

**Response:** !<ID>'TG'<value>(CR)

### 20.5.21 Software reset

**Description:** This command is used to trigger a software reset

**Request:** <ID>'RS1'(CR)

<ID> Device address (2 decimal places with leading zeros)

**Response:** !<ID>'RS'<value>(CR)

### 20.5.22 Switchover to binary protocol

**Description:** This command is used to temporarily switch over to UMB protocol. If the switchover is to be permanent, the sensor must be configured accordingly with the aid of the UMB-Config-Tool.

**Request:** <ID>'XX'(CR)

<ID> Device address (2 decimal places with leading zeros)

**Response:** '!<ID>'XX'(CR)

### 20.5.23 CRC Calculation

The CRC is calculated in accordance with the following rule:

The check sum is exclusive or an (XOR) of all characters of the telegram including the separators ',' but excluding '\$' and '\*'. The hexadecimal value of the upper and lower 4 bits of the result are converted into two ASCII characters (0-9,A-F) for transmission. The high byte is transmitted first.

Further information on the description of a CRC calculation is available in the NMEA 0183 protocol.

## 20.6 Communication in SDI-12 Mode

The communication in the SDI-12 mode of the WSxxx is conforming to the standard defined in 'SDI-12 A Serial-Digital Interface Standard for Microprocessor-Based Sensors Version 1.3 January 12, 2009'. The station may be operated in bus mode together with other SDI-12 sensors, connected to one SDI master (logger).

### 20.6.1 Preconditions for SDI-12 Operation

As the interface settings defined in the SDI-12 standard are significantly different from the UMB default settings, some preconditions have to be met for operation:

- Hardware version equal or higher 3.0
- Software version equal or higher 1.5
- Jumper for activation of SDI-12 mode has to be wired (see below)
- Setting for SDI-12 mode in the configuration (via Config Tool)

To activate the SDI-12 mode a jumper is to be wired between control input and analog ground (pins 3 and 6 of the of the UMB round connector, or red and blue wires of the connection cable).

Using the Config Tool the operation mode of the station has to be set to "SDI-12", parity to 7E1 and the baudrate to 1200Bd. The serial interface must be operated in half duplex mode

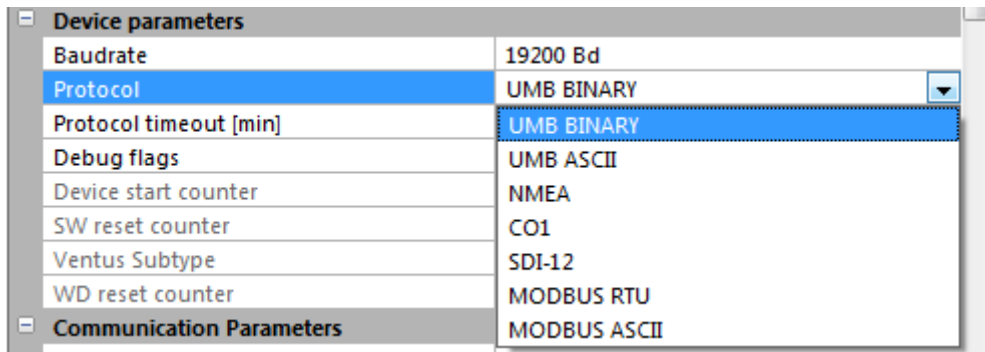

Figure 19: Setting the SDI-12 protocol

Measurement data can be transmitted alternatively in metric or US units. The selection is done by the UMB Config Tool.

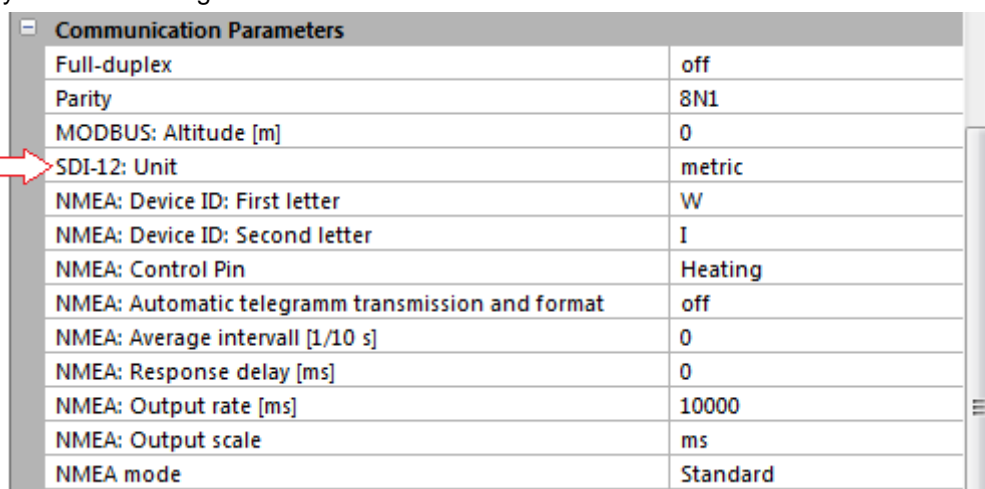

Figure 20: Setting the unit

When operating the device in SDI-12 mode it is basically no longer possible to access the device with the UMB Config Tool, due to the different interface parameter settings. To enable configuration access nevertheless the interface is operated in standard UMB mode for the first 5 seconds after reset / power on. If a valid UMB telegram is received within this time, the device

will stay in UMB mode for the configured time out (several minutes) so that the configuration can be modified.:

- Connect the PC to the **Ventus** through an RS-485 converter
- Start the Config Tool and create a **Ventus** with the address of the actual device and activate at least one sensor. Start the measurement (will report connection error at first)
- Reset the device (Power off / on)
- When measurement values are received the measurement can be terminated, the interface is now open for configuration.

### 20.6.2 Command Set

Due the applied measurement processes the **Ventus** will, different from other sensors described in the SDI-12 document, always measure continuously. This causes some special properties:

- The device does not need a "Wakeup" and does not have a sleep mode. So the reactions to "Break" signals and any related timings are inapplicable. "Break" will be ignored by WS devices.
- Data requested with M- or C- commands are always available immediately. The device will always respond with a000n resp. a000nn . This means the device will not send any service request and will ignore measurement abort signals. The logger should request the data immediately.
- M- and C- command only differ in the number of values made available in the buffers (in both cases up to the maximum permitted by the standard of 9 resp. 20).
- We recommend to use the commands für continuous measurement (R-commands) to request the data.



For details of the SDI-12 protocol please refer to the above mentioned standard document.

Following commands are available for the *Ventus*:

Befehl	Funktion
?!	Address search (Wildcard request, one device only on bus!)
a!	Request device active?
al!	Request device identification
aAb!	Address change to b ( 0 ... 9, A ...Z, a ... z)
aM!	Measurement, minimal base data set
aM1!	Measurement, Temperature Values
aM2!	Measurement: Wind Values
aM3!	Measurement: Air Pressure Values
aMC!	Measurement,minimal base data set, transmit values with CRC
aMC1! ... aMC3!	Measurement, (value assignment as for aMn! commands), transmission with CRC
aC!	Concurrent measurement, complete base data set
aC1! ... aC3!	Concurrent measurement, (value assignment as for aMn! Commands), extended data set
aCC!	Concurrent measurement, complete data set,, transmit values with CRC
aCC1! ... aCC3!	Concurrent measurement, complete data set,, (value assignment as for aMn! Commands), extended data set , transmit values with CRC
aD0!	Data request buffer 0
aD1!	Data request buffer 1
aD2!	Data request buffer 2
aD3!	Data request buffer 3
aD4!	Data request buffer 4
aR0!	Data request from continuous measurement, data set 0
aR1!	Data request from continuous measurement, data set 1
aR2!	Data request from continuous measurement, data set 2
aR3!	Data request from continuous measurement, data set 3
aR4!	Data request from continuous measurement, data set 4
aRC0!	Data request from continuous measurement, data set 0 with CRC
aRC1!	Data request from continuous measurement, data set 1 with CRC
aRC2!	Data request from continuous measurement, data set 2 with CRC
aRC3!	Data request from continuous measurement, data set 3 with CRC
aRC4!	Data request from continuous measurement, data set 4 with CRC
aV!	Command verification: Evaluate sensor status and heating temperatures, data request with aD0!, aD1!
aXU<m/u>!	Selection of the unit system for SDI12 data
aXH+nnnn!	Adjust the local altitude for calculation of relative air pressure
aXMn!	Select the heating mode of the device (
aXR!	Device Reset

**Note:** The examples in the following sections use italics to print the requests from the logger ( *0V!* )

### 20.6.3 Address Configuration

UMB Device-ID and SDI-12 Address are connected, but the different address ranges and the fact, that UMB ID's are integer numbers, while SDI-12 addresses are ASCII characters, have to be considered.

UMB Device ID1 (default) corresponds to SDI-12 Address '0' (SDI-12 default).

Valid Address Ranges:

UMB			SDI-12		
1	to	10	'0'	to	'9'
18	to	43	'A'	to	'Z'
50	to	75	'a'	to	'z'

### 20.6.4 Measurement Data Messages

In the interest of simplified evaluation the assignment of measurement values to data buffers '0' ... '9' has been defined unified for all measurement commands. For this reason the responses to C-requests are restricted to 35 characters, not using the 75 characters permitted for these requests

Currently buffers '0' bis '4' are in use.

As with M-requests max. 9 values may be transmitted, the minimal base data set has been assigned to buffers '0' and '1'. Buffers '2' to '4', which are available on request by C commands, contain further measurement values. This definition guaranties the compatibility to loggers designed according to older versions of the SDI-12 standard.

The complete range of measurement values, as defined for the UMB protocol, is available in the SDI-12 environment through the additional M and C commands (aM1! ... aM3!, aMC1! ... aMC3!, aC1! ... aC3!, aCC1! ... aCC3!).

If the measurement value is not available for some reason, e.g. sensor failure, this is indicated by a value of +999.0 or -999.9. The logger can then evaluate the reason of failure by a aV! verification request.

The following tables show the measurement values in the sequence they are arranged in the telegram (see example).

Depending on the configuration of the device the values will be transmitted in metric or US units.

**Note:** The configured system of units is not indicated in the data messages. The logger may request this setting with the I-command and adjust the evaluation of the data messages accordingly

Example: M Request

0M!

00009<CR><LF> 9 Values are available

0D0!

0+13.5+2.5+3.7+2.6<CR><LF>

Air temperature 13,5°C, curr.. wind speed 2,5m/s, max. Wind speed 3,7m/s, avg.wind speed 2,6m/s

0D1!

0+136.4+134.0+100.0+1010.4+1.160<CR><LF>

Curr. wind direction 136,4°, avg. wind direction(vct) 134,0°, Qualityof wind measurement 100%, rel. air presssure (curr) 1010.4 hPa, air density 1.16kg/m³



Example: C Request

```

0C!
000019<CR><LF>          18 Values available
0D0!
0+13.5+2.5+3.7+2.6<CR><LF>
Air temperature 13,5°C, curr.. wind speed 2,5m/s, max. Wind speed 3,7m/s, avg.wind speed 2,6m/s
0D1!
0+136.4+134.0+100.0+1010.4+1.160<CR><LF>
Curr. wind direction 136,4°, avg. wind direction(vct) 134,0°, Quality of wind measurement 100%, rel. air pressure (curr)
1010.4 hPa, air density 1.16kg/m³
0D2!
0+1.8+2.8+122.0+147.0<CR><LF>
Wind speed (min) 1,8m/s, Wind speed (vct)2,8m/s,Wind direction (min) 122,0°,Wind direction (max) 147,0°
0D3!
0+12.4+14.0+13.5<CR><LF>
Air temperature (min) 12,4°C, air temperature (max) 14,0°C, air temperature (avg) 13,5°C
0D4!
0+1008.2+1011.2+1009.1<CR><LF>
Rel. air pressure (min) 1008.2 hPa,rel. air pressure (max) 1011.7 hPa, rel. air pressure (avg) 1009.1 hPa
    
```

20.6.4.1 Buffer Assignment Base Data Set

**Device configured for measurement values in metric units:**

Measurement value	UMB Channel	Min	Max	Unit
<b>Buffer '0'</b>				
Air temperature (act)	100	-50.0	70.0	°C
Wind Speed(act)	400	0.0	90.0	m/s
Wind Speed (max)	440	0.0	90.0	m/s
Wind Speed (avg)	460	0.0	90.0	m/s
<b>Buffer '1'</b>				
Wind Direction (act)	500	0.0	359.9	°
Wind Direction (vct)	580	0.0	359.9	°
Wind Quality	805	0.0	100,0	%
Rel. Air Pressure (act)	305	300.0	1200.0	hPa
Air Density (act)	310	0.000	3.000	kg/m³
<b>Buffer '2'</b>				
Wind Speed(min)	420	0.0	90.0	m/s
Wind Speed(vct)	480	0.0	90.0	m/s
Wind Direction (min)	520	0.0	359.9	°
Wind Direction (max)	540	0.0	359.9	°
<b>Buffer '3'</b>				
Air temperature (min)	120	-50.0	70.0	°C
Air temperature (max)	140	-50.0	70.0	°C
Air temperature (avg)	160	-50.0	70.0	°C
<b>Buffer '4'</b>				
Rel. Air Pressure (min)	325	300.0	1200.0	hPa
Rel. Air Pressure (max)	345	300.0	1200.0	hPa
Rel. Air Pressure (avg)	365	300.0	1200.0	hPa

**Device configured for measurement values in US units:**

Measurement Value	UMB Channel	Min	Max	Unit
<b>Buffer '0'</b>				
Air Temperature (act)	105	-58.0	158.0	°F
Wind Speed(act)	410	0.0	201.3	Mph
Wind Speed (max)	450	0.0	201.3	mph
Wind Speed (avg)	470	0.0	201.3	mph
<b>Buffer '1'</b>				
Wind Direction (act)	500	0.0	359.9	°
Wind Direction (vct)	580	0.0	359.9	°
Wind Quality	805	0.0	100.0	%
Rel. Air Pressure (act)	305	300.0	1200.0	hPa
Air Density (act)	310	0.000	3.000	kg/m <sup>3</sup>
<b>Buffer '2'</b>				
Wind Speed(min)	430	0.0	201.3	mph
Wind Speed(vct)	490	0.0	201.3	mph
Wind Direction (min)	520	0.0	359.9	°
Wind Direction (max)	540	0.0	359.9	°
<b>Buffer '3'</b>				
Air temperature (min)	125	-58.0	158.0	°F
Air temperature (max)	145	-58.0	158.0	°F
Air temperature (avg)	165	-58.0	158.0	°F
<b>Buffer '4'</b>				
Rel. Air Pressure (min)	325	300.0	1200.0	hPa
Rel. Air Pressure (max)	345	300.0	1200.0	hPa
Rel. Air Pressure (avg)	365	300.0	1200.0	hPa

**20.6.5 Additional Measurement Commands**

With the additional measurement commands

aM1! ... aM3!

aMC1! ... aMC3! (M command, data transmission with CRC)

aC1! ... aC3!

aCC1! ... aCC3! (C command, data transmission with CRC)

the complete range of measurement data of the *Ventus*, as defined for the UMB protocol, is also available in a SDI-12 environment.

The measurement values are grouped according to sensor types.

As for the base data, an M command only permits to request up to 9 measurement values. With C commands, up to 20 values are available.

The buffer assignment defined below is thus structured in a way, that the resp. M command uses the D0 and D1 buffers. If more values are available for the sensor type, the C command will also fill the buffers D2 to D4 (if required)

M1 / C1	Temperature	M: 4 Values	C: 4 Values
M2 / C2	Wind	M: 9 Values	C: 10 Values
M3 / C3	Air Pressure	M: 8 Values	C: 8 Values

## 20.6.5.1 Buffer Assignment Additional Measurement Data M1 / C1 Temperature

**Device configured for measurement values in metric units**

Measurement value	UMB Channel	Min	Max	Unit
<b>Buffer '0'</b>				
Air temperature (act)	100	-50.0	70.0	°C
Air temperature (min)	120	-50.0	70.0	°C
Air temperature (max)	140	-50.0	70.0	°C
Air temperature (avg)	160	-50.0	70.0	°C

**Device configured for measurement values in US units:**

Measurement value	UMB Channel	Min	Max	Unit
<b>Buffer '0'</b>				
Air temperature (act)	105	-58.0	158.0	°F
Air temperature (min)	125	-58.0	158.0	°F
Air temperature (max)	145	-58.0	158.0	°F
Air temperature (avg)	165	-58.0	158.0	°F

## 20.6.5.2 Buffer Assignment Additional Measurement Data M2 / C2 Wind

**Device configured for measurement values in metric units:**

Measurement value	UMB Channel	Min	Max	Unit
<b>Buffer '0'</b>				
Wind Speed (act)	400	0.0	90,0	m/s
Wind Speed (min)	420	0.0	90,0	m/s
Wind Speed (max)	440	0.0	90,0	m/s
Wind Speed (avg)	460	0.0	90,0	m/s
Wind Speed (vct)	480	0.0	90,0	m/s
<b>Buffer '1'</b>				
Wind Direction (act)	500	0.0	359.9	°
Wind Direction (min)	520	0.0	359.9	°
Wind Direction (max)	540	0.0	359.9	°
Wind Direction (vct)	580	0.0	359.9	°
<b>Buffer '2'</b>				
Wind Measurement Quality	805	0.0	100.0	%
Wind Gust Speed	443	0.0	90.0	m/s
Wind Gust Direction	543	0.0	359.9	°

**Device configured for measurement values in US units:**

Measurement value	UMB Channel	Min	Max	Unit
<b>Buffer '0'</b>				
Wind Speed (act)	410	0.0	201.3	Mph
Wind Speed (min)	430	0.0	201.3	Mph
Wind Speed (max)	450	0.0	201.3	mph
Wind Speed (avg)	470	0.0	201.3	mph
Wind Speed (vct)	490	0.0	201.3	mph
<b>Buffer '1'</b>				
Wind Direction (act)	500	0.0	359.9	°
Wind Direction (min)	520	0.0	359.9	°
Wind Direction (max)	540	0.0	359.9	°
Wind Direction (vct)	580	0.0	359.9	°
<b>Buffer '2'</b>				
Wind Measurement Quality	805	0.0	100.0	%
Wind Gust Speed	453	0.0	201.3	mph
Wind Gust Direction	543	0.0	359.9	°

## 20.6.5.3 Buffer Assignment Additional Measurement Data M3 / C3 Air Pressure

**Device configured for measurement values in metric or US units:**

Measurement value	UMB Channel	Min	Max	Unit
<b>Buffer '0'</b>				
Abs. Air Pressure (act)	300	300.0	1200.0	hPa
Abs. Air Pressure(min)	320	300.0	1200.0	hPa
Abs. Air Pressure (max)	340	300.0	1200.0	hPa
Abs. Air Pressure (avg)	360	300.0	1200.0	hPa
<b>Buffer '1'</b>				
Rel. Air Pressure (act)	305	300.0	1200.0	hPa
Rel. Air Pressure(min)	325	300.0	1200.0	hPa
Rel. Air Pressure (max)	345	300.0	1200.0	hPa
Rel. Air Pressure (avg)	365	300.0	1200.0	hPa
<b>Buffer '2'</b>				
Air Density (act)	310	0.000	3.000	kg/m <sup>3</sup>

**20.6.6 Message Device Identification**

The device responds to the identification request with following message (example for SDI-12 device address '0':

```
0I!
013Lufft.deVentusy00
y: Metric / US units ( m = metric, u = US )
```

i.e. for a **Ventus**, configured for US units:

```
0I!
013Lufft.deVentusu00
```

### 20.6.7 Message Verifikation

The command verification aV! is used to evaluate status information of the device. The device responds with

a0004<CR<LF>

to the request, i.e. 4 values are available in the buffers.

The first 2 “measurement values”, transmitted in buffer ‘0’ contain the status information of the measurement channels.

The status data of the channels are arranged into “fake” measurement values, each digit representing on status value. The coding of the status is listed below. Generally each sensor has to status values, one for the current measurement value, and one for the value buffer, which is used for averaging and the evaluation of minimum and maximum.

The last two values, transmitted in buffer ‘1’, show the heating temperatures of the upper and the lower heating of the wind sensor.

Buffer ‘0’				
Status Group 1: +nnnn	Air temperatur, air temperature buffer, air pressure,, air pressure buffer			
Status Group 2: +nn	Wind, wind buffer			
Buffer ‘1’, device configured for metric units				
Measurement value	UMB Channel	min	max	Unit
Heating temp. top	112	-50	+150	°C
Heating temp. bottom	113	-50	+150	°C
Buffer ‘1’, device configured for US units				
Heating temp. top	117	-58	+302	°F
Heating temp. bottom	118	-58	+302	°F

Sensor status	Code
OK	0
UNGLTG_KANAL	1
E2_CAL_ERROR E2_CRC_KAL_ERR FLASH_CRC_ERR FLASH_WRITE_ERR FLASH_FLOAT_ERR	2
MEAS_ERROR	3
MEAS_UNABLE	4
INIT_ERROR	5
VALUE_OVERFLOW CHANNEL_OVERRANGE	6
VALUE_UNDERFLOW CHANNEL_UNDERRANGE	7
BUSY	8
Any other sensor status	9

Table 1: Sensor status codes SDI-12

Example (SDI-12 Address ‘0’, no error):

```
0V!  
00004<CR><LF>  
0D0!  
0+0000+00<CR><LF>
```

```
0D1!
0+73.0+65.3<CR><LF>
```

Example (SDI-12 Address '0', temperature sensor failure):

```
0V!
00004<CR><LF>
0D0!
0+0300+00<CR><LF>
0D1!
0+73.0+65.3<CR><LF>
```

### 20.6.8 Message Selection of Measurement Unit System

The command is used to change the unit system used for the display of the SDI-12 data between metric and US units. The command is implemented as X command

Command: aXU<u/m>!

Response: aU<u/m><CR><LF>

u: US-Units, m: Metric Units

Example Select metric units

```
0XUm!
0Um<CR><LF>
```

### 20.6.9 Message Adjustment of the Altitude

For the calculation of the relative air pressure the local altitude (above sea level) of the device is required

Command: aXH+nnnn!

nnnn: Altitude of Sensor in m

Response: aXH+nnnn<CR><LF>

The assignment of an invalid altitude ( -100 < altitude < 5000) will be answered with aXHf<CR><LF>

Example: The altitude of the location of installation is 135m

```
0XH+135!
0XH+135<CR><LF>
```

### 20.6.10 Message setting of the Heating Mode

The heating of the sensor may be configured in different modes (see 6.3.1 and 12.2.6).

The SDI12 command sets combinations of heating operation mode and heating power mode.

Command: aXMn!

n: Heating Mode (0: Off, 1: Automatic/full power, 2: Automatic/alternating)

Response: aXMnm<CR><LF>

n: selected heating mode (0: Off, 1: automatic)

m: selected power mode (0: full, 1: alternating)

The assignment of an invalid heating mode will be answered with

aXMf<CR><LF>

Example: A *Ventus* shall be set to Automatic/Alternating

```
0XM2!
0XM11<CR><LF>
```



## 20.7 Communication in Modbus Mode

To enable the integration of **Ventus** wind meters into PLC and similar environments communication with Modbus protocols is provided.

Measurement values are mapped to Modbus input registers. The range of available values is basically the same as for the UMB protocol, including the translation into different unit systems (metric, imperial ...).

In the interest of safe and simple commissioning we do not use register pairs for floating point or 32 bit integers, as the use of register pairs is not described in the Modbus standard documents. All measurement values are scaled to fit into 16bit integer registers.

### 20.7.1 Modbus Communication Parameters

The **Ventus** may be configured for MODBUS-RTU or MODBUS-ASCII.

For basic configuration the UMB Config Tool is used.

**Note:** If the **Ventus** has been configured for Modbus communication, analog output functions can not be used!

If MODBUS-RTU or MODBUS-ASCII has been selected as communication protocol in the UMB Config Tool, communication parameters are preset to 19200 Bd, even parity.

Modbus operating modes: MODBUS-RTU, MODBUS-ASCII

Baudrate: 19200 (9600, 4800 or less)

Interface settings 8E1, 8N1

**Note:** **Ventus** Modbus communication has been tested with 1 sec poll rate. Proper function of the device will not be guaranteed for higher poll rates.

We suggest to set the poll rate to 10 sec or slower, because generally the update rate of the measurement values is 10 sec or higher (except of the fast wind speed / wind direction channels)

Anyway for most of the weather data significant changes should be expected more in the range of minutes.

### 20.7.2 Addressing

The Modbus address is equal to the UMB address. Valid Modbus addresses are 1 to 247. If a higher UMB address has been selected, the Modbus address will be set to 247.

### 20.7.3 Modbus Functions

The functions of Conformance Class 0 and 1 have been implemented, as far as they are applicable for **Ventus**, i.e. all functions working on register level.

	<b>Conformance Class 0</b>	
0x03	Read Holding Registers	Selected configuration settings
0x16	Write Multiple Registers	Selected configuration settings
	<b>Conformance Class 1</b>	
0x04	Read Input Registers	Measurement values and status information
0x06	Write Single Register	Selected configuration settings
0x07	Read Exception Status	Currently not used (returns 0)
	<b>Diagnostics</b>	
0x11	Report Slave ID	(replies to broadcast address as well)

## 20.7.3.1 Function 0x03 Read Holding Registers

The Holding Registers are used to make a selected set of adjustable parameters available on Modbus also. Similar to the measurement values are mapped to 16bit integer values, if necessary by appropriate scaling

Reg. Adr.	Reg. Addr.	Function	Values	Scale
1	0	Local Altitude	Altitude in m, for calculation of relative air pressure Value range -100 ... 5000	1.0
2	1	Heating operating mode	High-Byte: Heating Operating Mode *) Low-Byte Heating Power Mode *) For details see 6.3.1 and 12.2.6	
3	2	Stationsreset	(function when writing only, returns always 0)	

\*) Value Range High-Byte (Operating Mode):

0	Off
1	Automatic
2	Test Mode (maintenance only)
3	Off,if ext.control line „high“, otherwise automatic
4	Off,if ext.control line „low“, otherwise automatic

\*) Value range Low-Byte (Power Mode)

0	Full heating power
1	Reduced heating power, alternating lower and upper heating element

The register value is calculated as (power mode) + 256 \* (operating mode),  
e.g. full power, automatic:  $0 + 256 * 1 = 256$ , or reduced power,automatic:  $1 + 256 * 1 = 257$

## 20.7.3.2 Function 0x06 Write Holding Register, 0x10 Write Multiple Registers

Selected parameters of the **Ventus** can be adjusted by writing to the Modbus holding registers. Register assignment see above 20.7.3.1.

The values are checked for plausibility. Improper values will not be accepted and cause a Modbus exception.

Writing the value 0x3247 (12871d) into register no. 3 (register adr. 2) will trigger a device reset.

### 20.7.3.3 Function 0x04 Read Input Registers

The input registers are containing the measurement values of the compact weather station and the related status information.

The measurement values are mapped to the 16bit registers using scaling factors (0 ... max. 65530 for unsigned values, -32762 ... 32762 for signed values).

Values 65535 (0xffff) resp. 32767 are used for the indication of erroneous or not available measurement values. A more detailed specification of the error can be evaluated from the status registers.

The assignment of values to the available register addresses (0 ... 124) has been arranged in a way so that the user can read the most frequently used data with few (ideally only one) register block requests

Following blocks have been defined:

- Status information
- Frequently used values which are independent of the unit system (metric / imperial) in use
- Frequently used values in metric units
- Frequently used values in imperial units
- Other measurement values

When using the metric unit system the first three blocks can supply all data usually required with one request.

There is no difference in the register assignment between the sub types of the WS family. If, dependent on the type, some value is not available, this will be indicated by setting the register to the error value..

For detailed information about measurement ranges, units etc. please refer to the related description of the UMB channels (Chapter 8 and 20.1)

Reg. No.	Reg. Addr.	Value (UMB-Channel)	Range	Scaling, signed/unsigned, remarks
<b>Status information</b>				
1	0	Identification	High Byte: Device Subtype LowByte: Software Version	
2	1	Device status	Device status unequal 0 indicates a serious problem when reading the configuration storage or during system start. Please contact Luft Service with reference to the indicated code.	
3	2	Sensorstatus 1	Air temperature buffer, air temperature, air pressure buffer, air pressure (High byte -> low byte, see table below)	Coding 4 bit per status, s. below
4	3	Sensorstatus 2	Windbuffer, wind (high byte, see table below)	Coding 4 bit per status, s. below
5	4	Reserved		
6	5	Reserved		
7	6	Reserved		
8	7	Reserved		
9	8	Reserved		
10	9		Diagnostics: run time in 10sec steps	

Reg. No.	Reg. Addr.	Value (UMB-Channel)	Range	Scaling, signed/unsigned, remarks
<b>Values Independent of the Unit System</b>				
11	10	305	Rel. Air Pressure (act.)	Factor 10, s
12	11	325	Rel. Air Pressure (min.)	Factor 10, s
13	12	345	Rel. Air Pressure (max.)	Factor 10, s
14	13	365	Rel. Air Pressure (avg.)	Factor 10, s
15	14	500	Wind Direction (act.)	Factor 10, s
16	15	520	Wind Direction (min.)	Factor 10, s
17	16	540	Wind Direction (max.)	Factor 10, s
18	17	580	Wind Direction (vct.)	Factor 10, s
19	18	805	Wind Measurement Quality	Factor 1, s

Reg. No.	Reg. Addr.	Value (UMB-Channel)	Range	Scaling, signed/unsigned, remarks
<b>Values in Metric Units</b>				
20	19	100	Air Temperature °C (act.)	Factor 10, s
21	20	120	Air Temperature °C (min.)	Factor 10, s
22	21	140	Air Temperature °C (max.)	Factor 10, s
23	22	160	Air Temperature °C (avg.)	Factor 10, s
24	23	112	Heating Temperature top °C	Factor 10, s
25	24	113	Heating Temperature bottom °C	Factor 10, s
26	25	400	Wind Speed m/s (act.)	Factor 10, s
27	26	420	Wind Speed m/s (min.)	Factor 10, s
28	27	440	Wind Speed m/s (max.)	Factor 10, s
29	28	460	Wind Speed m/s (avg.)	Factor 10, s
30	29	480	Wind Speed m/s (vct.)	Factor 10, s

Reg. No.	Reg. Addr.	Value (UMB-Channel)	Range	Scaling, signed/unsigned, remarks
<b>Values in US Units</b>				
31	30	105	Air Temperature °F (act.)	Factor 10, s
32	31	125	Air Temperature °F (min.)	Factor 10, s
33	32	145	Air Temperature °F (max.)	Factor 10, s
34	33	165	Air Temperature °F (avg.)	Factor 10, s
35	34	117	Heating Temperature top °F	Factor 10, s
36	35	118	Heating Temperature bottom °F	Factor 10, s
37	36	410	Wind Speed mph (act.)	Factor 10, s
38	37	430	Wind Speed mph (min.)	Factor 10, s
39	38	450	Wind Speed mph (max.)	Factor 10, s
40	39	470	Wind Speed mph (avg.)	Factor 10, s
41	40	490	Wind Speed mph (vct.)	Factor 10, s

Reg. No.	Reg. Addr.	Value (UMB-Channel)	Range	Scaling, signed/unsigned, remarks
<b>Additional Measurement Values</b>				
42	41	300	Abs. Air Pressure (act.)	Factor 10, s
43	42	320	Abs. Air Pressure (min.)	Factor 10, s
44	43	340	Abs. Air Pressure (max.)	Factor 10, s
45	44	360	Abs. Air Pressure (avg.)	Factor 10, s
46	45	405	Wind Speed km/h (act.)	Factor 10, s
47	46	425	Wind Speed km/h (min.)	Factor 10, s
48	47	445	Wind Speed km/h (max.)	Factor 10, s
49	48	465	Wind Speed km/h (avg.)	Factor 10, s
50	49	485	Wind Speed km/h (vct.)	Factor 10, s
51	50	415	Wind Speed kts (act.)	Factor 10, s
52	51	435	Wind Speed kts (min.)	Factor 10, s
53	52	455	Wind Speed kts (max.)	Factor 10, s
54	53	475	Wind Speed kts (avg.)	Factor 10, s
55	54	495	Wind Speed kts (vct.)	Factor 10, s
56	55	310	Air Density kg/m <sup>3</sup> (act.)	Factor 1000, u
57	56	443	Wind Gust Speed m/s	Factor 10, s
58	57	543	Wind Gust Direction	Factor 10, s
59	58	448	Wind Gust Speed km/h	Factor 10, s
60	59	453	Wind Gust Speed mph	Factor 10, s
61	60	458	Wind Gust Speed kts	Factor 10, s
	...	Reserve		
125	124			

#### 20.7.4 Sensor Status:

Each register holds 4 sensor status coded with 4 bits per status. The sequence defined in the table above is to understand as from most significant half byte to least significant half byte. Most of the sensors have two status values, one for the sensor itself and the current measurement value, another one for the buffer, from which average, min. And max values are evaluated.

#### Assignment of Status Information to Status Register

Register	Byte	Half-Byte	Status
Sensor Status 1	High	High	Temperature Buffer
		Low	Temperature
	Low	High	Air Pressure Buffer
		Low	Air Pressure
Sensor Status 2	High	High	Wind Buffer
		Low	Wind
	Low	High	0
		Low	0

**Example Sensor Status 1:**

Temperature buffer status, temperature status, air pressure buffer status, air pressure status

High Byte		Low Byte	
High	Low	High	Low
Temperature-Buffer	Temperature	Air Pressure Buffer	Air Pressure
5	3	0	7

The example values above (for illustration only, the given combination will not occur in reality) are combined to the register value 0x5307 = 21255.

The single status are retrieved from the register as integer part of

- Status 1 = register / 4096
- Status 2 = ( register / 256 ) AND 0x000F
- Status 3 = ( register / 16 ) AND 0x000F
- Status 4 = register AND 0x000F

Following table shows the status coding:

Sensor State	Code
OK	0
UNGLTG_KANAL	1
E2_CAL_ERROR E2_CRC_KAL_ERR FLASH_CRC_ERR FLASH_WRITE_ERR FLASH_FLOAT_ERR	2
MEAS_ERROR, MEAS_UNABLE	3
INIT_ERROR	4
VALUE_OVERFLOW CHANNEL_OVERRANGE VALUE_UNDERFLOW CHANNEL_UNDERRANGE	5
BUSY	6
Other Sensor State	7

Table 2: Coding of Sensor Status

## 21 List of Figures

Figure 1: Measurement Sections.....	6
Figure 2 Influence of Wind on Time of Flight.....	7
Figure 3 Example of Wind Gust Evaluation .....	10
Figure 4 Fastening to the Mast.....	14
Figure 5 North Markings.....	15
Figure 6 Alignment to North .....	15
Figure 7 Installations Sketch .....	17
Figure 8 Connections .....	18
Figure 9 Connection to ISOCON-UMB.....	20
Figure 10: Sensor selection.....	23
Figure 11: Device settings.....	24
Figure 12: Communication Parameters.....	25
Figure 13: Heating Parameters .....	26
Figure 14: Wind Parameters .....	26
Figure 15: Analog Outputs .....	27
Figure 16: Channel list .....	29
Figure 17: Data query.....	30
Figure 18: Drawing <i>Ventus</i> .....	34
Figure 19: Setting the SDI-12 protocol .....	55
Figure 20: Setting the unit .....	55



**22 Keyword Index**

<b>A</b>		Interface.....	19
Accessories.....	5	ISOCON-UMB .....	21
Accuracy.....	33	<b>K</b>	
ASCII-Protocol.....	43	Klassen-ID .....	40
<b>B</b>		<b>M</b>	
Binary Protocol.....	40	Maintenance .....	31
<b>C</b>		Measurement Output .....	11
Channel List Summary .....	38	Measurements .....	9
Channel List Summary per TLS2002 .....	39	Measuring Range .....	33
Class-ID .....	40, 41	Modbus .....	65
Commissioning.....	22	<b>N</b>	
Communication .....	65	NMEA .....	45
Communication .....	43, 45	North Alignment.....	15
Connections .....	18	<b>O</b>	
CRC Calculation.....	54	Operating conditions.....	32
<b>D</b>		Order Number .....	5
Designated Use.....	4	<b>P</b>	
Device-ID.....	41	Protection type.....	32
Dimensions.....	32	<b>S</b>	
Disposal .....	37	Safety Instructions .....	4
Drawing.....	34	Supply Voltage.....	19
<b>Declaration of Conformity .....</b>	<b>35</b>	Symbols.....	4
<b>E</b>		<b>S</b>	
Error-Codes.....	42, 44	Storage conditions .....	32
<b>F</b>		<b>T</b>	
Fault Description .....	36	Technical Data .....	32
<b>H</b>		Technical Support.....	37
Heating.....	7, 32	<b>W</b>	
<b>I</b>		Warranty .....	4, 37
Installation .....	14	Weight.....	32

**G. Lufft Mess- und  
Regeltechnik GmbH**

**Lufft Germany**

**Fellbach**

Gutenbergstrasse 20  
70736 Fellbach  
Postal address:  
PO Box 4252  
70719 Fellbach  
Phone: +49 711 51822-0  
Fax: +49 711 51822-41  
info@lufft.de  
www.lufft.com

**Berlin**

Carl-Scheele-Strasse 16  
12489 Berlin  
Phone: +49 711 51822-831  
Fax: +49 711 51822-944  
info@lufft.de  
www.lufft.com

*a passion for precision · passion pour la précision · pasión por la precisión · passione per la precisione · a p*

**Lufft North America**

**Lufft USA, Inc.**

1110 Eugenia Pl. Unit B  
Carpinteria, CA 93013, USA  
Phone: +1 919 556 0818  
Fax: +1 805 845 4275  
sales@lufftusainc.com  
www.lufft.com

**Lufft China**

**Lufft (Shanghai)  
Measurement & Control  
Technology Co., Ltd.**

Room 507 & 509, Building No.3,  
Shanghai Yinshi Science and  
Business Park,  
No. 2568 Gudai Road,  
Minhang District,  
201199 Shanghai, China  
Phone: +86 21 5437 0890  
Fax: +86 21 5437 0910  
china@lufft.com  
www.lufft.com

